

# ESP32 Series

## Datasheet

### Including:

ESP32-D0WD

ESP32-D0WDQ6

ESP32-D2WD

ESP32-S0WD



*Version 2.4*

*Espressif Systems*

*Copyright © 2018*

## About This Guide

This document provides the specifications of ESP32 family of chips.

## Revision History

For any changes to this document over time, please refer to the [last page](#).

## Documentation Change Notification

Espressif provides email notifications to keep customers updated on changes to technical documentation. Please subscribe at [www.espressif.com/en/subscribe](http://www.espressif.com/en/subscribe).

## Certification

Download certificates for Espressif products from [www.espressif.com/en/certificates](http://www.espressif.com/en/certificates).

## Disclaimer and Copyright Notice

Information in this document, including URL references, is subject to change without notice. THIS DOCUMENT IS PROVIDED AS IS WITH NO WARRANTIES WHATSOEVER, INCLUDING ANY WARRANTY OF MERCHANTABILITY, NON-INFRINGEMENT, FITNESS FOR ANY PARTICULAR PURPOSE, OR ANY WARRANTY OTHERWISE ARISING OUT OF ANY PROPOSAL, SPECIFICATION OR SAMPLE.

All liability, including liability for infringement of any proprietary rights, relating to use of information in this document is disclaimed. No licenses express or implied, by estoppel or otherwise, to any intellectual property rights are granted herein. The Wi-Fi Alliance Member logo is a trademark of the Wi-Fi Alliance. The Bluetooth logo is a registered trademark of Bluetooth SIG.

All trade names, trademarks and registered trademarks mentioned in this document are property of their respective owners, and are hereby acknowledged.

Copyright © 2018 Espressif Inc. All rights reserved.

# Contents

<b>1</b>	<b>Overview</b>	<b>1</b>
1.1	Featured Solutions	1
1.1.1	Ultra-Low-Power Solution	1
1.1.2	Complete Integration Solution	1
1.2	Wi-Fi Key Features	1
1.3	BT Key Features	2
1.4	MCU and Advanced Features	2
1.4.1	CPU and Memory	2
1.4.2	Clocks and Timers	3
1.4.3	Advanced Peripheral Interfaces	3
1.4.4	Security	3
1.5	Applications	4
1.6	Block Diagram	5
<b>2</b>	<b>Pin Definitions</b>	<b>6</b>
2.1	Pin Layout	6
2.2	Pin Description	7
2.3	Power Scheme	9
2.4	Strapping Pins	11
<b>3</b>	<b>Functional Description</b>	<b>12</b>
3.1	CPU and Memory	12
3.1.1	CPU	12
3.1.2	Internal Memory	12
3.1.3	External Flash and SRAM	13
3.1.4	Memory Map	13
3.2	Timers and Watchdogs	15
3.2.1	64-bit Timers	15
3.2.2	Watchdog Timers	15
3.3	System Clocks	16
3.3.1	CPU Clock	16
3.3.2	RTC Clock	16
3.3.3	Audio PLL Clock	16
3.4	Radio	16
3.4.1	2.4 GHz Receiver	17
3.4.2	2.4 GHz Transmitter	17
3.4.3	Clock Generator	17
3.5	Wi-Fi	17
3.5.1	Wi-Fi Radio and Baseband	17
3.5.2	Wi-Fi MAC	18
3.6	Bluetooth	18
3.6.1	Bluetooth Radio and Baseband	18
3.6.2	Bluetooth Interface	19
3.6.3	Bluetooth Stack	19

3.6.4	Bluetooth Link Controller	19
3.7	RTC and Low-Power Management	20
<b>4</b>	<b>Peripherals and Sensors</b>	<b>22</b>
4.1	Descriptions of Peripherals and Sensors	22
4.1.1	General Purpose Input / Output Interface (GPIO)	22
4.1.2	Analog-to-Digital Converter (ADC)	22
4.1.3	Hall Sensor	23
4.1.4	Digital-to-Analog Converter (DAC)	23
4.1.5	Touch Sensor	23
4.1.6	Ultra-Lower-Power Co-processor	23
4.1.7	Ethernet MAC Interface	23
4.1.8	SD/SDIO/MMC Host Controller	24
4.1.9	SDIO/SPI Slave Controller	24
4.1.10	Universal Asynchronous Receiver Transmitter (UART)	25
4.1.11	I2C Interface	25
4.1.12	I2S Interface	25
4.1.13	Infrared Remote Controller	25
4.1.14	Pulse Counter	25
4.1.15	Pulse Width Modulation (PWM)	25
4.1.16	LED PWM	26
4.1.17	Serial Peripheral Interface (SPI)	26
4.1.18	Accelerator	26
4.2	Peripheral Pin Configurations	27
<b>5</b>	<b>Electrical Characteristics</b>	<b>32</b>
5.1	Absolute Maximum Ratings	32
5.2	Recommended Operating Conditions	32
5.3	DC Characteristics (3.3V, 25°C)	32
5.4	Reliability Qualifications	33
5.5	RF Power-Consumption Specifications	33
5.6	Wi-Fi Radio	34
5.7	Bluetooth Radio	34
5.7.1	Receiver – Basic Data Rate	34
5.7.2	Transmitter – Basic Data Rate	35
5.7.3	Receiver – Enhanced Data Rate	35
5.7.4	Transmitter – Enhanced Data Rate	36
5.8	Bluetooth LE Radio	37
5.8.1	Receiver	37
5.8.2	Transmitter	37
<b>6</b>	<b>Package Information</b>	<b>38</b>
<b>7</b>	<b>Part Number and Ordering Information</b>	<b>39</b>
<b>8</b>	<b>Learning Resources</b>	<b>40</b>
8.1	Must-Read Documents	40

8.2	Must-Have Resources	40
	<b>Appendix A – ESP32 Pin Lists</b>	41
A.1.	Notes on ESP32 Pin Lists	41
A.2.	GPIO_Matrix	44
A.3.	Ethernet_MAC	49
A.4.	IO_MUX	49
	<b>Revision History</b>	51

## List of Tables

1	Pin Description	7
2	Description of ESP32 Power-up and Reset Timing Parameters	10
3	Strapping Pins	11
4	Memory and Peripheral Mapping	14
5	Power Consumption by Power Modes	20
6	ADC Characteristics	22
7	ADC Calibration Results	22
8	Capacitive-Sensing GPIOs Available on ESP32	23
9	Peripheral Pin Configurations	27
10	Absolute Maximum Ratings	32
11	Recommended Operating Conditions	32
12	DC Characteristics	32
13	Reliability Qualifications	33
14	RF Power-Consumption Specifications	33
15	Wi-Fi Radio Characteristics	34
16	Receiver Characteristics – Basic Data Rate	34
17	Transmitter Characteristics – Basic Data Rate	35
18	Receiver Characteristics – Enhanced Data Rate	35
19	Transmitter Characteristics – Enhanced Data Rate	36
20	Receiver Characteristics – BLE	37
21	Transmitter Characteristics – BLE	37
22	ESP32 Ordering Information	39
23	Notes on ESP32 Pin Lists	41
24	GPIO_Matrix	44
25	Ethernet_MAC	49

## List of Figures

1	Functional Block Diagram	5
2	ESP32 Pin Layout (QFN 6*6, Top View)	6
3	ESP32 Pin Layout (QFN 5*5, Top View)	7
4	ESP32 Power Scheme	9
5	ESP32 Power-up and Reset Timing	10
6	Address Mapping Structure	13
7	QFN48 (6x6 mm) Package	38
8	QFN48 (5x5 mm) Package	38
9	ESP32 Part Number	39

# 1. Overview

ESP32 is a single 2.4 GHz Wi-Fi-and-Bluetooth combo chip designed with the TSMC ultra-low-power 40 nm technology. It is designed to achieve the best power and RF performance, showing robustness, versatility and reliability in a wide variety of applications and power scenarios.

The ESP32 series of chips includes ESP32-D0WDQ6, ESP32-D0WD, ESP32-D2WD, and ESP32-S0WD. For details on part numbers and ordering information, please refer to [Part Number and Ordering Information](#).

## 1.1 Featured Solutions

### 1.1.1 Ultra-Low-Power Solution

ESP32 is designed for mobile, wearable electronics, and Internet-of-Things (IoT) applications. It features all the state-of-the-art characteristics of low-power chips, including fine-grained clock gating, multiple power modes, and dynamic power scaling. For instance, in a low-power IoT sensor hub application scenario, ESP32 is woken up periodically and only when a specified condition is detected. Low-duty cycle is used to minimize the amount of energy that the chip expends. The output of the power amplifier is also adjustable, thus contributing to an optimal trade-off between communication range, data rate and power consumption.

**Note:**

For more information, refer to Section 3.7 RTC and Low-Power Management.

### 1.1.2 Complete Integration Solution

ESP32 is a highly-integrated solution for Wi-Fi-and-Bluetooth IoT applications, with around 20 external components. ESP32 integrates an antenna switch, RF balun, power amplifier, low-noise receive amplifier, filters, and power management modules. As such, the entire solution occupies minimal Printed Circuit Board (PCB) area.

ESP32 uses CMOS for single-chip fully-integrated radio and baseband, while also integrating advanced calibration circuitries that allow the solution to remove external circuit imperfections or adjust to changes in external conditions. As such, the mass production of ESP32 solutions does not require expensive and specialized Wi-Fi testing equipment.

## 1.2 Wi-Fi Key Features

- 802.11 b/g/n
- 802.11 n (2.4 GHz), up to 150 Mbps
- WMM
- TX/RX A-MPDU, RX A-MSDU
- Immediate Block ACK
- Defragmentation
- Automatic Beacon monitoring (hardware TSF)
- 4 × virtual Wi-Fi interfaces



- Simultaneous support for Infrastructure Station, SoftAP, and Promiscuous modes  
Note that when ESP32 is in Station mode, performing a scan, the SoftAP channel will be changed.
- Antenna diversity

**Note:**

For more information, please refer to Section [3.5 Wi-Fi](#).

## 1.3 BT Key Features

- Compliant with Bluetooth v4.2 BR/EDR and BLE specifications
- Class-1, class-2 and class-3 transmitter without external power amplifier
- Enhanced Power Control
- +12 dBm transmitting power
- NZIF receiver with -97 dBm BLE sensitivity
- Adaptive Frequency Hopping (AFH)
- Standard HCI based on SDIO/SPI/UART
- High-speed UART HCI, up to 4 Mbps
- Bluetooth 4.2 BR/EDR BLE dual mode controller
- Synchronous Connection-Oriented/Extended (SCO/eSCO)
- CVSD and SBC for audio codec
- Bluetooth Piconet and Scatternet
- Multi-connections in Classic BT and BLE
- Simultaneous advertising and scanning

## 1.4 MCU and Advanced Features

### 1.4.1 CPU and Memory

- Xtensa® single-/dual-core 32-bit LX6 microprocessor(s), up to 600 MIPS (200 MIPS for ESP32-S0WD, 400 MIPS for ESP32-D2WD)
- 448 kB ROM
- 520 kB SRAM
- 16 kB SRAM in RTC
- QSPI supports multiple flash/SRAM chips

### 1.4.2 Clocks and Timers

- Internal 8 MHz oscillator with calibration
- Internal RC oscillator with calibration
- External 2 MHz ~ 60 MHz crystal oscillator (40 MHz only for Wi-Fi/BT functionality)
- External 32 kHz crystal oscillator for RTC with calibration
- Two timer groups, including 2 x 64-bit timers and 1 x main watchdog in each group
- One RTC timer
- RTC watchdog

### 1.4.3 Advanced Peripheral Interfaces

- 34 x programmable GPIOs
- 12-bit SAR ADC up to 18 channels
- 2 x 8-bit DAC
- 10 x touch sensors
- 4 x SPI
- 2 x I2S
- 2 x I2C
- 3 x UART
- 1 host (SD/eMMC/SDIO)
- 1 slave (SDIO/SPI)
- Ethernet MAC interface with dedicated DMA and IEEE 1588 support
- CAN 2.0
- IR (TX/RX)
- Motor PWM
- LED PWM up to 16 channels
- Hall sensor

### 1.4.4 Security

- Secure boot
- Flash encryption
- 1024-bit OTP, up to 768-bit for customers
- Cryptographic hardware acceleration:
  - AES
  - Hash (SHA-2)
  - RSA
  - ECC

- Random Number Generator (RNG)

## 1.5 Applications

- Generic low-power IoT sensor hub
- Generic low-power IoT loggers
- Cameras for video streaming
- Over The Top (OTT) devices
- Music players
  - Internet music players
  - Audio streaming devices
- Wi-Fi-enabled toys
  - Loggers
  - Proximity sensing toys
- Wi-Fi-enabled speech recognition devices
- Audio headsets
- Smart power plugs
- Home automation
- Mesh network
- Industrial wireless control
- Baby monitors
- Wearable electronics
- Wi-Fi-enabled location-tracking devices
- Security ID tags
- Healthcare
  - Proximity- and movement-monitoring devices
  - Temperature data loggers

## 1.6 Block Diagram

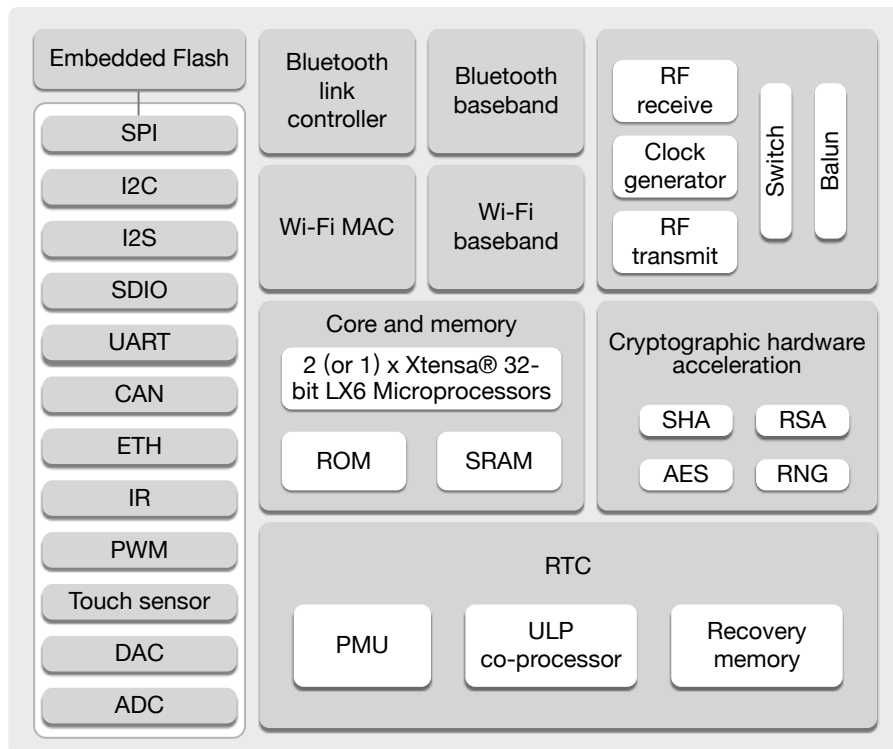

Figure 1: Functional Block Diagram

**Note:**

Products in the ESP32 series differ from each other in terms of their support for embedded flash and the number of CPUs they have. For details, please refer to [Part Number and Ordering Information](#).

## 2. Pin Definitions

### 2.1 Pin Layout

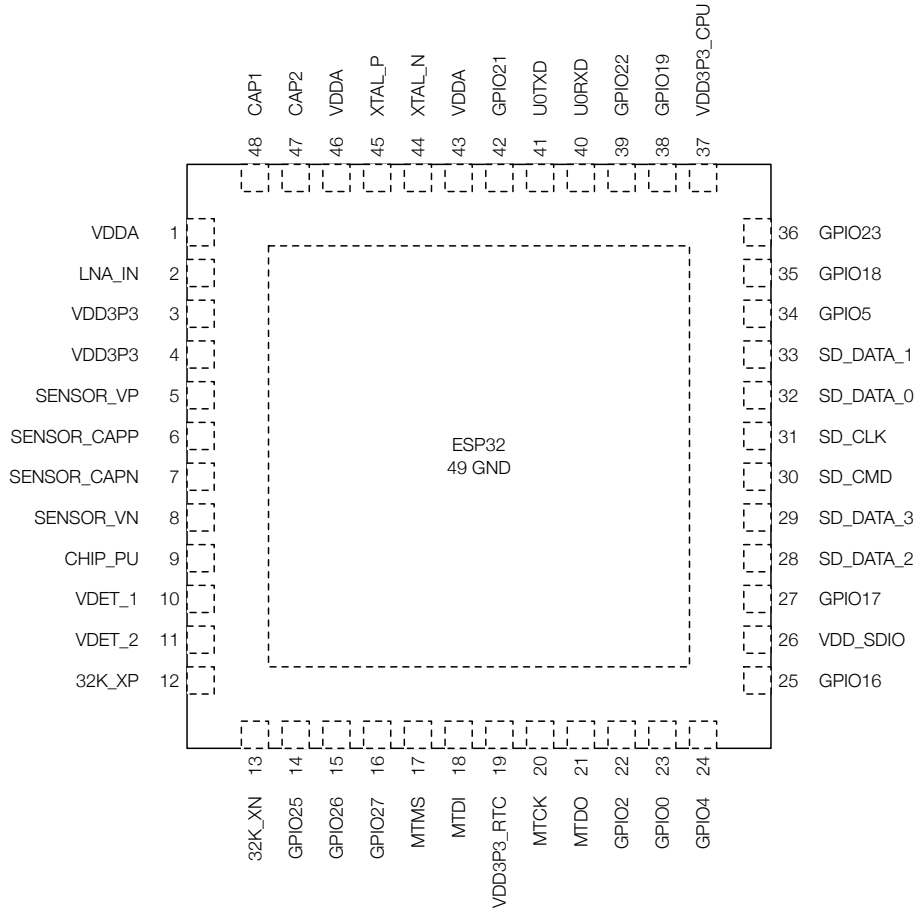

Figure 2: ESP32 Pin Layout (QFN 6\*6, Top View)

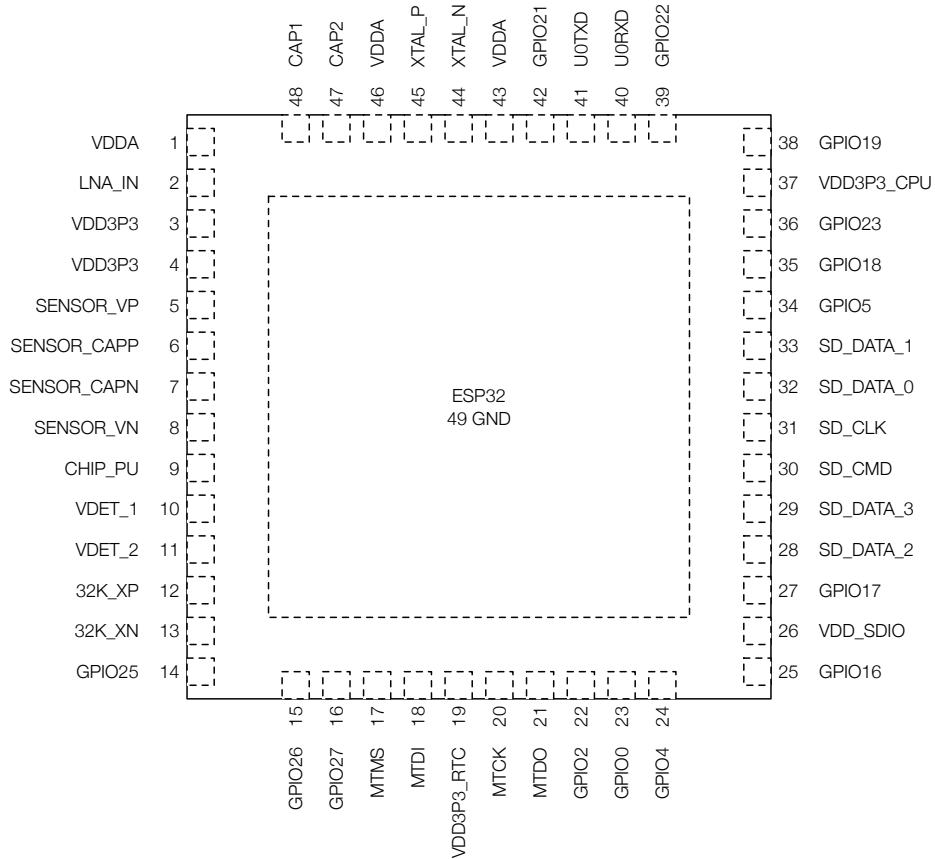

Figure 3: ESP32 Pin Layout (QFN 5\*5, Top View)

**Note:**

For details on ESP32's part numbers and the corresponding packaging, please refer to [Part Number and Ordering Information](#).

## 2.2 Pin Description

Table 1: Pin Description

Name	No.	Type	Function
Analog			
VDDA	1	P	Analog power supply (2.3V ~ 3.6V)
LNA_IN	2	I/O	RF input and output
VDD3P3	3	P	Analog power supply (2.3V ~ 3.6V)
VDD3P3	4	P	Analog power supply (2.3V ~ 3.6V)
VDD3P3_RTC			
SENSOR_VP	5	I	GPIO36, ADC1_CH0, RTC_GPIO0
SENSOR_CAPP	6	I	GPIO37, ADC1_CH1, RTC_GPIO1
SENSOR_CAPN	7	I	GPIO38, ADC1_CH2, RTC_GPIO2
SENSOR_VN	8	I	GPIO39, ADC1_CH3, RTC_GPIO3

Name	No.	Type	Function
CHIP_PU	9	I	High: On; enables the chip Low: Off; resets the chip Note: Do not leave the CHIP_PU pin floating.
VDET_1	10	I	GPIO34, ADC1_CH6, RTC_GPIO4
VDET_2	11	I	GPIO35, ADC1_CH7, RTC_GPIO5
32K_XP	12	I/O	GPIO32, 32K_XP (32.768 kHz crystal oscillator input), ADC1_CH4, TOUCH9, RTC_GPIO9
32K_XN	13	I/O	GPIO33, 32K_XN (32.768 kHz crystal oscillator output), ADC1_CH5, TOUCH8, RTC_GPIO8
GPIO25	14	I/O	GPIO25, DAC_1, ADC2_CH8, RTC_GPIO6, EMAC_RXD0
GPIO26	15	I/O	GPIO26, DAC_2, ADC2_CH9, RTC_GPIO7, EMAC_RXD1
GPIO27	16	I/O	GPIO27, ADC2_CH7, TOUCH7, RTC_GPIO17, EMAC_RX_DV
MTMS	17	I/O	GPIO14, ADC2_CH6, TOUCH6, RTC_GPIO16, MTMS, HSPICLK, HS2_CLK, SD_CLK, EMAC_TXD2
MTDI	18	I/O	GPIO12, ADC2_CH5, TOUCH5, RTC_GPIO15, MTDI, HSPIQ, HS2_DATA2, SD_DATA2, EMAC_TXD3
VDD3P3_RTC	19	P	Input power supply for RTC IO (2.3V ~ 3.6V)
MTCK	20	I/O	GPIO13, ADC2_CH4, TOUCH4, RTC_GPIO14, MTCK, HSPID, HS2_DATA3, SD_DATA3, EMAC_RX_ER
MTDO	21	I/O	GPIO15, ADC2_CH3, TOUCH3, RTC_GPIO13, MTDO, HSPICS0, HS2_CMD, SD_CMD, EMAC_RXD3
GPIO2	22	I/O	GPIO2, ADC2_CH2, TOUCH2, RTC_GPIO12, HSPIWP, HS2_DATA0, SD_DATA0
GPIO0	23	I/O	GPIO0, ADC2_CH1, TOUCH1, RTC_GPIO11, CLK_OUT1, EMAC_TX_CLK
GPIO4	24	I/O	GPIO4, ADC2_CH0, TOUCH0, RTC_GPIO10, HSPIHD, HS2_DATA1, SD_DATA1, EMAC_TX_ER
VDD_SDIO			
GPIO16	25	I/O	GPIO16, HS1_DATA4, U2RXD, EMAC_CLK_OUT
VDD_SDIO	26	P	Output power supply: 1.8V or the same voltage as VDD3P3_RTC
GPIO17	27	I/O	GPIO17, HS1_DATA5, U2TXD, EMAC_CLK_OUT_180
SD_DATA_2	28	I/O	GPIO9, SD_DATA2, SPIHD, HS1_DATA2, U1RXD
SD_DATA_3	29	I/O	GPIO10, SD_DATA3, SPIWP, HS1_DATA3, U1TXD
SD_CMD	30	I/O	GPIO11, SD_CMD, SPICS0, HS1_CMD, U1RTS
SD_CLK	31	I/O	GPIO6, SD_CLK, SPICLK, HS1_CLK, U1CTS
SD_DATA_0	32	I/O	GPIO7, SD_DATA0, SPIQ, HS1_DATA0, U2RTS
SD_DATA_1	33	I/O	GPIO8, SD_DATA1, SPID, HS1_DATA1, U2CTS
VDD3P3_CPU			
GPIO5	34	I/O	GPIO5, VSPICS0, HS1_DATA6, EMAC_RX_CLK
GPIO18	35	I/O	GPIO18, VSPICLK, HS1_DATA7
GPIO23	36	I/O	GPIO23, VSPID, HS1_STROBE
VDD3P3_CPU	37	P	Input power supply for CPU IO (1.8V ~ 3.6V)
GPIO19	38	I/O	GPIO19, VSPIQ, U0CTS, EMAC_TXD0
GPIO22	39	I/O	GPIO22, VSPIWP, U0RTS, EMAC_TXD1

Name	No.	Type	Function
U0RXD	40	I/O	GPIO3, U0RXD, CLK_OUT2
U0TXD	41	I/O	GPIO1, U0TXD, CLK_OUT3, EMAC_RXD2
GPIO21	42	I/O	GPIO21, VSPIHD, EMAC_TX_EN
Analog			
VDDA	43	P	Analog power supply (2.3V ~ 3.6V)
XTAL_N	44	O	External crystal output
XTAL_P	45	I	External crystal input
VDDA	46	P	Analog power supply (2.3V ~ 3.6V)
CAP2	47	I	Connects to a 3 nF capacitor and 20 k $\Omega$ resistor in parallel to CAP1
CAP1	48	I	Connects to a 10 nF series capacitor to ground
GND	49	P	Ground

**Note:**

- ESP32-D2WD's pins GPIO16, GPIO17, SD\_CMD, SD\_CLK, SD\_DATA\_0 and SD\_DATA\_1 are used for connecting the embedded flash, and are not recommended for other uses.
- For a quick reference guide to using the IO\_MUX, Ethernet MAC, and GPIO Matrix pins of ESP32, please refer to Appendix [ESP32 Pin Lists](#).
- In most cases, the data port connection between the ESP32 and external flash is as follows: SD\_DATA0/SPIQ = IO1/DO, SD\_DATA1/SPID = IO0/DI, SD\_DATA2/SPIHD = IO3/HOLD#, SD\_DATA3/SPIWP = IO2/WP#.

## 2.3 Power Scheme

ESP32's digital pins are divided into three different power domains:

- VDD3P3\_RTC
- VDD3P3\_CPU
- VDD\_SDIO

VDD3P3\_RTC is also the input power supply for RTC and CPU.

VDD3P3\_CPU is also the input power supply for CPU.

VDD\_SDIO connects to the output of an internal LDO whose input is VDD3P3\_RTC. When VDD\_SDIO is connected to the same PCB net together with VDD3P3\_RTC, the internal LDO is disabled automatically. The power scheme diagram is shown below:

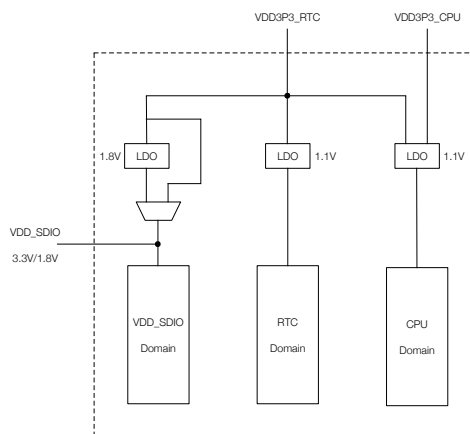

**Figure 4: ESP32 Power Scheme**



The internal LDO can be configured as having 1.8V, or the same voltage as VDD3P3\_RTC. It can be powered off via software to minimize the current of flash/SRAM during the Deep-sleep mode.

#### Notes on CHIP\_PU:

- The illustration below shows the ESP32 power-up and reset timing. Details about the parameters are listed in Table 2.

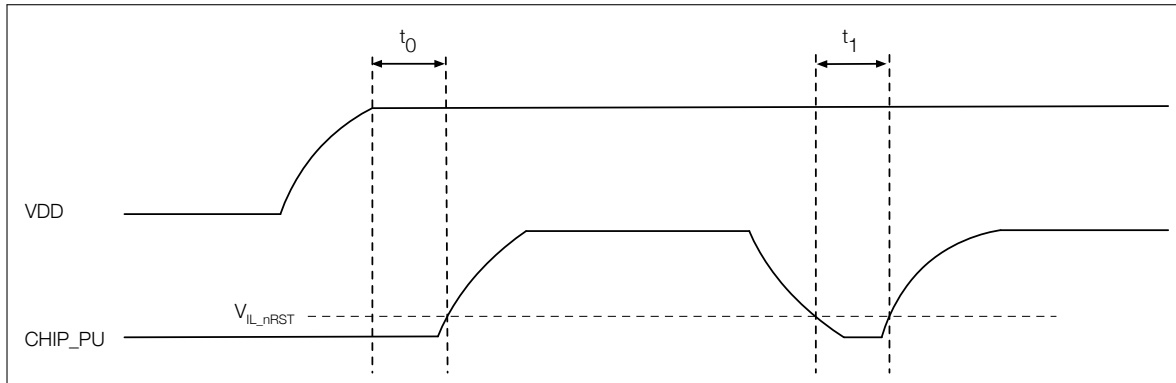

Figure 5: ESP32 Power-up and Reset Timing

Table 2: Description of ESP32 Power-up and Reset Timing Parameters

Parameters	Description	Min.	Unit
$t_0$	Time between the 3.3V rails being brought up and CHIP_PU being activated	50	$\mu\text{s}$
$t_1$	Duration of CHIP_PU signal level $< V_{IL\_nRST}$ (refer to its value in Table 12 DC Characteristics) to reset the chip	50	$\mu\text{s}$

- In scenarios where ESP32 is powered on and off repeatedly by switching the power rails, while there is a large capacitor on the VDD33 rail and CHIP\_PU and VDD33 are connected, simply switching off the CHIP\_PU power rail and immediately switching it back on may cause an incomplete power discharge cycle and failure to reset the chip adequately.

An additional discharge circuit may be required to accelerate the discharge of the large capacitor on rail VDD33, which will ensure proper power-on-reset when the ESP32 is powered up again. Please find the discharge circuit in Figure **ESP32-WROOM-32 Peripheral Schematics**, in [ESP32-WROOM-32 Datasheet](#).

- When a battery is used as the power supply for the ESP32 series of chips and modules, a supply voltage supervisor is recommended, so that a boot failure due to low voltage is avoided. Users are recommended to pull CHIP\_PU low if the power supply for ESP32 is below 2.3V. For the reset circuit, please refer to Figure **ESP32-WROOM-32 Peripheral Schematics**, in [ESP32-WROOM-32 Datasheet](#).

#### Notes on power supply:

- The operating voltage of ESP32 ranges from 2.3V to 3.6V. When using a single-power supply, the recommended voltage of the power supply is 3.3V, and its recommended output current is 500 mA or more.
- When VDD\_SDIO 1.8V is used as the power supply for external flash/PSRAM, a 2-kohm grounding resistor should be added to VDD\_SDIO. For the circuit design, please refer to Figure **ESP32-WROVER Schematics**, in [ESP32-WROVER Datasheet](#).
- When the three digital power supplies are used to drive peripherals, e.g., 3.3V flash, they should comply with the peripherals' specifications.

## 2.4 Strapping Pins

ESP32 has five strapping pins:

- MTDI
- GPIO0
- GPIO2
- MTDO
- GPIO5

Software can read the values of these five bits from register "GPIO\_STRAPPING".

During the chip's system reset (power-on-reset, RTC watchdog reset and brownout reset), the latches of the strapping pins sample the voltage level as strapping bits of "0" or "1", and hold these bits until the chip is powered down or shut down. The strapping bits configure the device's boot mode, the operating voltage of VDD\_SDIO and other initial system settings.

Each strapping pin is connected to its internal pull-up/pull-down during the chip reset. Consequently, if a strapping pin is unconnected or the connected external circuit is high-impedance, the internal weak pull-up/pull-down will determine the default input level of the strapping pins.

To change the strapping bit values, users can apply the external pull-down/pull-up resistances, or use the host MCU's GPIOs to control the voltage level of these pins when powering on ESP32.

After reset, the strapping pins work as normal-function pins.

Refer to Table 3 for a detailed boot-mode configuration by strapping pins.

**Table 3: Strapping Pins**

Voltage of Internal LDO (VDD_SDIO)					
Pin	Default	3.3V		1.8V	
MTDI	Pull-down	0		1	
Bootling Mode					
Pin	Default	SPI Boot		Download Boot	
GPIO0	Pull-up	1		0	
GPIO2	Pull-down	Don't-care		0	
Enabling/Disabling Debugging Log Print over U0TXD During Bootling					
Pin	Default	U0TXD Toggling		U0TXD Silent	
MTDO	Pull-up	1		0	
Timing of SDIO Slave					
Pin	Default	Falling-edge Input Falling-edge Output	Falling-edge Input Rising-edge Output	Rising-edge Input Falling-edge Output	Rising-edge Input Rising-edge Output
MTDO	Pull-up	0	0	1	1
GPIO5	Pull-up	0	1	0	1

**Note:**

- Firmware can configure register bits to change the settings of "Voltage of Internal LDO (VDD\_SDIO)" and "Timing of SDIO Slave", after bootling.
- For ESP32 chips that contain an embedded flash, users need to note the logic level of MTDI. For example, ESP32-D2WD contains an embedded flash that operates at 1.8V, therefore, the MTDI should be pulled high.

## 3. Functional Description

This chapter describes the functions integrated in ESP32.

### 3.1 CPU and Memory

#### 3.1.1 CPU

ESP32 contains one or two low-power Xtensa® 32-bit LX6 microprocessor(s) with the following features:

- 7-stage pipeline to support the clock frequency of up to 240 MHz (160 MHz for ESP32-S0WD and ESP32-D2WD)
- 16/24-bit Instruction Set provides high code-density
- Support for Floating Point Unit
- Support for DSP instructions, such as a 32-bit multiplier, a 32-bit divider, and a 40-bit MAC
- Support for 32 interrupt vectors from about 70 interrupt sources

The single-/dual-CPU interfaces include:

- Xtensa RAM/ROM Interface for instructions and data
- Xtensa Local Memory Interface for fast peripheral register access
- External and internal interrupt sources
- JTAG for debugging

#### 3.1.2 Internal Memory

ESP32's internal memory includes:

- 448 kB of ROM for booting and core functions
- 520 kB of on-chip SRAM for data and instructions
- 8 kB of SRAM in RTC, which is called RTC FAST Memory and can be used for data storage; it is accessed by the main CPU during RTC Boot from the Deep-sleep mode.
- 8 kB of SRAM in RTC, which is called RTC SLOW Memory and can be accessed by the co-processor during the Deep-sleep mode.
- 1 kbit of eFuse: 256 bits are used for the system (MAC address and chip configuration) and the remaining 768 bits are reserved for customer applications, including flash-encryption and chip-ID.
- Embedded flash

**Note:**

- Products in the ESP32 series differ from each other, in terms of their support for embedded flash and the size of it. For details, please refer to [Part Number and Ordering Information](#).
- ESP32-D2WD has a 16-Mbit, 40-MHz embedded flash, connected via pins GPIO16, GPIO17, SD\_CMD, SD\_CLK, SD\_DATA\_0 and SD\_DATA\_1.

### 3.1.3 External Flash and SRAM

ESP32 supports multiple external QSPI flash and SRAM chips. More details can be found in Chapter SPI in the [ESP32 Technical Reference Manual](#). ESP32 also supports hardware encryption/decryption based on AES to protect developers' programs and data in flash.

ESP32 can access the external QSPI flash and SRAM through high-speed caches.

- Up to 16 MB of external flash can be mapped into CPU instruction memory space and read-only memory space simultaneously.
  - When external flash is mapped into CPU instruction memory space, up to 11 MB+248 KB can be mapped at a time. Note that if more than 3 MB+248 KB are mapped, cache performance will be reduced due to speculative reads by the CPU.
  - When external flash is mapped into read-only data memory space, up to 4 MB can be mapped at a time. 8-bit, 16-bit and 32-bit reads are supported.
- External SRAM can be mapped into CPU data memory space. SRAM up to 8 MB is supported and up to 4 MB can be mapped at a time. 8-bit, 16-bit and 32-bit reads and writes are supported.

**Note:**

After ESP32 is initialized, firmware can customize the mapping of external SRAM or flash into the CPU address space.

### 3.1.4 Memory Map

The structure of address mapping is shown in Figure 6. The memory and peripheral mapping of ESP32 is shown in Table 4.

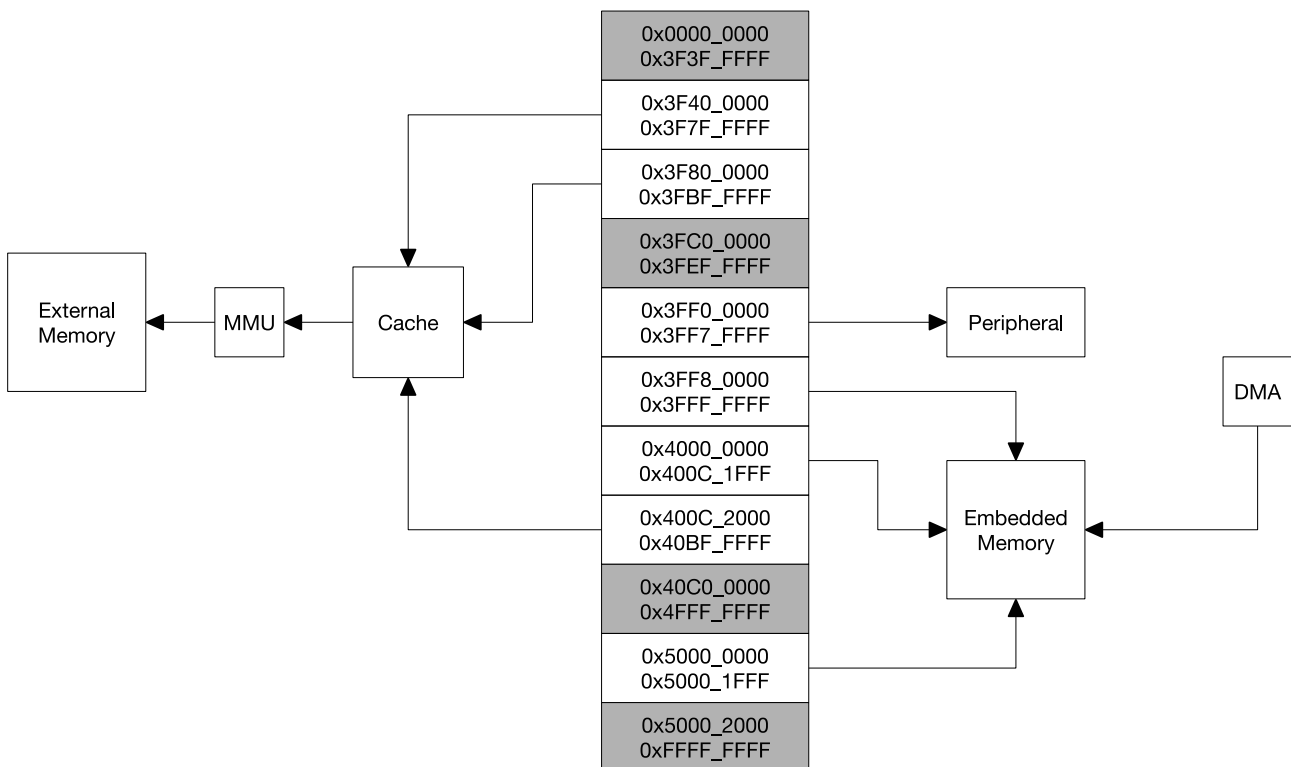

Figure 6: Address Mapping Structure

Table 4: Memory and Peripheral Mapping

Category	Target	Start Address	End Address	Size
Embedded Memory	Internal ROM 0	0x4000_0000	0x4005_FFFF	384 kB
	Internal ROM 1	0x3FF9_0000	0x3FF9_FFFF	64 kB
	Internal SRAM 0	0x4007_0000	0x4009_FFFF	192 kB
	Internal SRAM 1	0x3FFE_0000	0x3FFF_FFFF	128 kB
		0x400A_0000	0x400B_FFFF	
	Internal SRAM 2	0x3FFA_E000	0x3FFD_FFFF	200 kB
	RTC FAST Memory	0x3FF8_0000	0x3FF8_1FFF	8 kB
0x400C_0000		0x400C_1FFF		
RTC SLOW Memory	0x5000_0000	0x5000_1FFF	8 kB	
External Memory	External Flash	0x3F40_0000	0x3F7F_FFFF	4 MB
		0x400C_2000	0x40BF_FFFF	11 MB+248 kB
	External SRAM	0x3F80_0000	0x3FBF_FFFF	4 MB
Peripheral	DPort Register	0x3FF0_0000	0x3FF0_0FFF	4 kB
	AES Accelerator	0x3FF0_1000	0x3FF0_1FFF	4 kB
	RSA Accelerator	0x3FF0_2000	0x3FF0_2FFF	4 kB
	SHA Accelerator	0x3FF0_3000	0x3FF0_3FFF	4 kB
	Secure Boot	0x3FF0_4000	0x3FF0_4FFF	4 kB
	Cache MMU Table	0x3FF1_0000	0x3FF1_3FFF	16 kB
	PID Controller	0x3FF1_F000	0x3FF1_FFFF	4 kB
	UART0	0x3FF4_0000	0x3FF4_0FFF	4 kB
	SPI1	0x3FF4_2000	0x3FF4_2FFF	4 kB
	SPI0	0x3FF4_3000	0x3FF4_3FFF	4 kB
	GPIO	0x3FF4_4000	0x3FF4_4FFF	4 kB
	RTC	0x3FF4_8000	0x3FF4_8FFF	4 kB
	IO MUX	0x3FF4_9000	0x3FF4_9FFF	4 kB
	SDIO Slave	0x3FF4_B000	0x3FF4_BFFF	4 kB
	UDMA1	0x3FF4_C000	0x3FF4_CFFF	4 kB
	I2S0	0x3FF4_F000	0x3FF4_FFFF	4 kB
	UART1	0x3FF5_0000	0x3FF5_0FFF	4 kB
	I2C0	0x3FF5_3000	0x3FF5_3FFF	4 kB
	UDMA0	0x3FF5_4000	0x3FF5_4FFF	4 kB
	SDIO Slave	0x3FF5_5000	0x3FF5_5FFF	4 kB
	RMT	0x3FF5_6000	0x3FF5_6FFF	4 kB
	PCNT	0x3FF5_7000	0x3FF5_7FFF	4 kB
	SDIO Slave	0x3FF5_8000	0x3FF5_8FFF	4 kB
	LED PWM	0x3FF5_9000	0x3FF5_9FFF	4 kB
	Efuse Controller	0x3FF5_A000	0x3FF5_AFFF	4 kB
	Flash Encryption	0x3FF5_B000	0x3FF5_BFFF	4 kB
	PWM0	0x3FF5_E000	0x3FF5_EFFF	4 kB
	TIMG0	0x3FF5_F000	0x3FF5_FFFF	4 kB
	TIMG1	0x3FF6_0000	0x3FF6_0FFF	4 kB
	SPI2	0x3FF6_4000	0x3FF6_4FFF	4 kB

Category	Target	Start Address	End Address	Size
	SPI3	0x3FF6_5000	0x3FF6_5FFF	4 kB
	SYSCON	0x3FF6_6000	0x3FF6_6FFF	4 kB
	I2C1	0x3FF6_7000	0x3FF6_7FFF	4 kB
	SDMMC	0x3FF6_8000	0x3FF6_8FFF	4 kB
	EMAC	0x3FF6_9000	0x3FF6_AFFF	8 kB
	PWM1	0x3FF6_C000	0x3FF6_CFFF	4 kB
	I2S1	0x3FF6_D000	0x3FF6_DFFF	4 kB
	UART2	0x3FF6_E000	0x3FF6_EFFF	4 kB
	PWM2	0x3FF6_F000	0x3FF6_FFFF	4 kB
	PWM3	0x3FF7_0000	0x3FF7_0FFF	4 kB
	RNG	0x3FF7_5000	0x3FF7_5FFF	4 kB

## 3.2 Timers and Watchdogs

### 3.2.1 64-bit Timers

There are four general-purpose timers embedded in the ESP32. They are all 64-bit generic timers which are based on 16-bit prescalers and 64-bit auto-reload-capable up/down-timers.

The timers feature:

- A 16-bit clock prescaler, from 2 to 65536
- A 64-bit timer
- Configurable up/down timer: incrementing or decrementing
- Halt and resume of time-base counter
- Auto-reload at alarming
- Software-controlled instant reload
- Level and edge interrupt generation

### 3.2.2 Watchdog Timers

The ESP32 has three watchdog timers: one in each of the two timer modules (called the Main Watchdog Timer, or MWDT) and one in the RTC module (called the RTC Watchdog Timer, or RWDT). These watchdog timers are intended to recover from an unforeseen fault causing the application program to abandon its normal sequence. A watchdog timer has four stages. Each stage may trigger one of three or four possible actions upon the expiry of its programmed time period, unless the watchdog is fed or disabled. The actions are: interrupt, CPU reset, core reset, and system reset. Only the RWDT can trigger the system reset, and is able to reset the entire chip, including the RTC itself. A timeout value can be set for each stage individually.

During flash boot the RWDT and the first MWDT start automatically in order to detect, and recover from, booting problems.

The ESP32 watchdogs have the following features:

- Four stages, each of which can be configured or disabled separately
- A programmable time period for each stage

- One of three or four possible actions (interrupt, CPU reset, core reset, and system reset) upon the expiry of each stage
- 32-bit expiry counter
- Write protection that prevents the RWDT and MWDT configuration from being inadvertently altered
- SPI flash boot protection  
If the boot process from an SPI flash does not complete within a predetermined time period, the watchdog will reboot the entire system.

## 3.3 System Clocks

### 3.3.1 CPU Clock

Upon reset, an external crystal clock source is selected as the default CPU clock. The external crystal clock source also connects to a PLL to generate a high-frequency clock (typically 160 MHz).

In addition, ESP32 has an internal 8 MHz oscillator. The application can select the clock source from the external crystal clock source, the PLL clock or the internal 8 MHz oscillator. The selected clock source drives the CPU clock directly, or after division, depending on the application.

### 3.3.2 RTC Clock

The RTC clock has five possible sources:

- external low-speed (32 kHz) crystal clock
- external crystal clock divided by 4
- internal RC oscillator (typically about 150 kHz, and adjustable)
- internal 8 MHz oscillator
- internal 31.25 kHz clock (derived from the internal 8 MHz oscillator divided by 256)

When the chip is in the normal power mode and needs faster CPU accessing, the application can choose the external high-speed crystal clock divided by 4 or the internal 8 MHz oscillator. When the chip operates in the low-power mode, the application chooses the external low-speed (32 kHz) crystal clock, the internal RC clock or the internal 31.25 kHz clock.

### 3.3.3 Audio PLL Clock

The audio clock is generated by the ultra-low-noise fractional-N PLL. More details can be found in Chapter Reset and Clock in the [ESP32 Technical Reference Manual](#).

## 3.4 Radio

The ESP32 radio consists of the following blocks:

- 2.4 GHz receiver
- 2.4 GHz transmitter
- bias and regulators
- balun and transmit-receive switch

- clock generator

### 3.4.1 2.4 GHz Receiver

The 2.4 GHz receiver demodulates the 2.4 GHz RF signal to quadrature baseband signals and converts them to the digital domain with two high-resolution, high-speed ADCs. To adapt to varying signal channel conditions, RF filters, Automatic Gain Control (AGC), DC offset cancelation circuits and baseband filters are integrated with ESP32.

### 3.4.2 2.4 GHz Transmitter

The 2.4 GHz transmitter modulates the quadrature baseband signals to the 2.4 GHz RF signal, and drives the antenna with a high-powered Complementary Metal Oxide Semiconductor (CMOS) power amplifier. The use of digital calibration further improves the linearity of the power amplifier, enabling state-of-the-art performance in delivering up to +20.5 dBm of power for an 802.11b transmission and +18 dBm for an 802.11n transmission.

Additional calibrations are integrated to cancel any radio imperfections, such as:

- Carrier leakage
- I/Q phase matching
- Baseband nonlinearities
- RF nonlinearities
- Antenna matching

These built-in calibration routines reduce the amount of time required for product testing, and render the testing equipment unnecessary.

### 3.4.3 Clock Generator

The clock generator produces quadrature clock signals of 2.4 GHz for both the receiver and the transmitter. All components of the clock generator are integrated into the chip, including all inductors, varactors, filters, regulators and dividers.

The clock generator has built-in calibration and self-test circuits. Quadrature clock phases and phase noise are optimized on-chip with patented calibration algorithms which ensure the best performance of the receiver and the transmitter.

## 3.5 Wi-Fi

ESP32 implements a TCP/IP and full 802.11 b/g/n Wi-Fi MAC protocol. It supports the Basic Service Set (BSS) STA and SoftAP operations under the Distributed Control Function (DCF). Power management is handled with minimal host interaction to minimize the active-duty period.

### 3.5.1 Wi-Fi Radio and Baseband

The ESP32 Wi-Fi Radio and Baseband support the following features:

- 802.11b/g/n
- 802.11n MCS0-7 in both 20 MHz and 40 MHz bandwidth
- 802.11n MCS32 (RX)



- 802.11n 0.4  $\mu$ s guard-interval
- up to 150 Mbps of data rate
- Receiving STBC 2x1
- Up to 20.5 dBm of transmitting power
- Adjustable transmitting power
- Antenna diversity

ESP32 supports antenna diversity with an external RF switch. One or more GPIOs control the RF switch and selects the best antenna to minimize the effects of channel fading.

### 3.5.2 Wi-Fi MAC

The ESP32 Wi-Fi MAC applies low-level protocol functions automatically. They are as follows:

- 4  $\times$  virtual Wi-Fi interfaces
- Simultaneous Infrastructure BSS Station mode/SoftAP mode/Promiscuous mode
- RTS protection, CTS protection, Immediate Block ACK
- Defragmentation
- TX/RX A-MPDU, RX A-MSDU
- TXOP
- WMM
- CCMP (CBC-MAC, counter mode), TKIP (MIC, RC4), WAPI (SMS4), WEP (RC4) and CRC
- Automatic beacon monitoring (hardware TSF)

## 3.6 Bluetooth

ESP32 integrates a Bluetooth link controller and Bluetooth baseband, which carry out the baseband protocols and other low-level link routines, such as modulation/demodulation, packet processing, bit stream processing, frequency hopping, etc.

### 3.6.1 Bluetooth Radio and Baseband

The ESP32 Bluetooth Radio and Baseband support the following features:

- Class-1, class-2 and class-3 transmit output powers, and a dynamic control range of up to 24 dB
- $\pi/4$  DQPSK and 8 DPSK modulation
- High performance in NZIF receiver sensitivity with over 97 dB of dynamic range
- Class-1 operation without external PA
- Internal SRAM allows full-speed data-transfer, mixed voice and data, and full piconet operation
- Logic for forward error correction, header error control, access code correlation, CRC, demodulation, encryption bit stream generation, whitening and transmit pulse shaping
- ACL, SCO, eSCO and AFH
- A-law,  $\mu$ -law and CVSD digital audio CODEC in PCM interface

- SBC audio CODEC
- Power management for low-power applications
- SMP with 128-bit AES

### 3.6.2 Bluetooth Interface

- Provides UART HCI interface, up to 4 Mbps
- Provides SDIO / SPI HCI interface
- Provides PCM / I2S audio interface

### 3.6.3 Bluetooth Stack

The Bluetooth stack of ESP32 is compliant with the Bluetooth v4.2 BR / EDR and BLE specifications.

### 3.6.4 Bluetooth Link Controller

The link controller operates in three major states: standby, connection and sniff. It enables multiple connections, and other operations, such as inquiry, page, and secure simple-pairing, and therefore enables Piconet and Scatternet. Below are the features:

- Classic Bluetooth
  - Device Discovery (inquiry, and inquiry scan)
  - Connection establishment (page, and page scan)
  - Multi-connections
  - Asynchronous data reception and transmission
  - Synchronous links (SCO/eSCO)
  - Master/Slave Switch
  - Adaptive Frequency Hopping and Channel assessment
  - Broadcast encryption
  - Authentication and encryption
  - Secure Simple-Pairing
  - Multi-point and scatternet management
  - Sniff mode
  - Connectionless Slave Broadcast (transmitter and receiver)
  - Enhanced power control
  - Ping
- Bluetooth Low Energy
  - Advertising
  - Scanning
  - Simultaneous advertising and scanning
  - Multiple connections

- Asynchronous data reception and transmission
- Adaptive Frequency Hopping and Channel assessment
- Connection parameter update
- Data Length Extension
- Link Layer Encryption
- LE Ping

### 3.7 RTC and Low-Power Management

With the use of advanced power-management technologies, ESP32 can switch between different power modes.

- Power modes
  - Active mode: The chip radio is powered on. The chip can receive, transmit, or listen.
  - Modem-sleep mode: The CPU is operational and the clock is configurable. The Wi-Fi/Bluetooth base-band and radio are disabled.
  - Light-sleep mode: The CPU is paused. The RTC memory and RTC peripherals, as well as the ULP co-processor are running. Any wake-up events (MAC, host, RTC timer, or external interrupts) will wake up the chip.
  - Deep-sleep mode: Only the RTC memory and RTC peripherals are powered on. Wi-Fi and Bluetooth connection data are stored in the RTC memory. The ULP co-processor is functional.
  - Hibernation mode: The internal 8-MHz oscillator and ULP co-processor are disabled. The RTC recovery memory is powered down. Only one RTC timer on the slow clock and certain RTC GPIOs are active. The RTC timer or the RTC GPIOs can wake up the chip from the Hibernation mode.

**Table 5: Power Consumption by Power Modes**

Power mode	Description		Power consumption	
Active (RF working)	Wi-Fi Tx packet		Please refer to Table 14 for details.	
	Wi-Fi/BT Tx packet			
	Wi-Fi/BT Rx and listening			
Modem-sleep	The CPU is powered on.	240 MHz <sup>*</sup>	Dual-core chip(s)	30 mA ~ 68 mA
			Single-core chip(s)	N/A
		160 MHz <sup>*</sup>	Dual-core chip(s)	27 mA ~ 44 mA
			Single-core chip(s)	27 mA ~ 34 mA
		Normal speed: 80 MHz	Dual-core chip(s)	20 mA ~ 31 mA
			Single-core chip(s)	20 mA ~ 25 mA
Light-sleep	-		0.8 mA	
Deep-sleep	The ULP co-processor is powered on.		150 $\mu$ A	
	ULP sensor-monitored pattern		100 $\mu$ A @1% duty	
	RTC timer + RTC memory		10 $\mu$ A	
Hibernation	RTC timer only		5 $\mu$ A	
Power off	CHIP_PU is set to low level, the chip is powered off.		0.1 $\mu$ A	

**Note:**

- \* Among the ESP32 series of SoCs, ESP32-D0WDQ6 and ESP32-D0WD have a maximum CPU frequency of 240 MHz, ESP32-D2WD and ESP32-S0WD have a maximum CPU frequency of 160 MHz.
- When Wi-Fi is enabled, the chip switches between Active and Modem-sleep modes. Therefore, power consumption changes accordingly.
- In Modem-sleep mode, the CPU frequency changes automatically. The frequency depends on the CPU load and the peripherals used.
- During Deep-sleep, when the ULP co-processor is powered on, peripherals such as GPIO and I2C are able to operate.
- When the system works in the ULP sensor-monitored pattern, the ULP co-processor works with the ULP sensor periodically and the ADC works with a duty cycle of 1%, so the power consumption is 100  $\mu$ A.

## 4. Peripherals and Sensors

### 4.1 Descriptions of Peripherals and Sensors

#### 4.1.1 General Purpose Input / Output Interface (GPIO)

ESP32 has 34 GPIO pins which can be assigned various functions by programming the appropriate registers. There are several kinds of GPIOs: digital-only, analog-enabled, capacitive-touch-enabled, etc. Analog-enabled GPIOs and Capacitive-touch-enabled GPIOs can be configured as digital GPIOs.

Most of the digital GPIOs can be configured as internal pull-up or pull-down, or set to high impedance. When configured as an input, the input value can be read through the register. The input can also be set to edge-trigger or level-trigger to generate CPU interrupts. Most of the digital IO pins are bi-directional, non-inverting and tristate, including input and output buffers with tristate control. These pins can be multiplexed with other functions, such as the SDIO, UART, SPI, etc. (More details can be found in the Appendix, Table [IO\\_MUX](#).) For low-power operations, the GPIOs can be set to hold their states.

#### 4.1.2 Analog-to-Digital Converter (ADC)

ESP32 integrates 12-bit SAR ADCs and supports measurements on 18 channels (analog-enabled pins). The ULP-coprocessor in ESP32 is also designed to measure voltage, while operating in the sleep mode, which enables low-power consumption. The CPU can be woken up by a threshold setting and/or via other triggers.

With appropriate settings, the ADCs can be configured to measure voltage on 18 pins maximum.

Table 6 describes the ADC characteristics.

**Table 6: ADC Characteristics**

Parameter	Description	Min	Max	Unit
DNL (Differential nonlinearity)	RTC controller; ADC connected to an external 100 nF capacitor; DC signal input; ambient temperature at 25°C; Wi-Fi&BT off	-7	7	LSB
INL (Integral nonlinearity)		-12	12	LSB
Sampling rate	RTC controller	-	200	ksps
	DIG controller	-	2	Mpsps

#### Notes:

- When atten=3 and the measurement result is above 3,000 (voltage at approx. 2,450 mV), the ADC accuracy will be worse than described in the table above.
- To get better DNL results, users can take multiple sampling tests with a filter, or calculate the average value.

By default, there are  $\pm 6\%$  differences in measured results between chips. ESP-IDF provides couple of [calibration methods](#) for ADC1. Results after calibration using eFuse Vref value are shown in Table 7. For higher accuracy, users may apply other calibration methods provided in ESP-IDF, or implement their own.

**Table 7: ADC Calibration Results**

Parameter	Description	Min	Max	Unit
Total error	Atten=0, effective measurement range of 100–950 mV	-23	23	mV
	Atten=1, effective measurement range of 100–1,250 mV	-30	30	mV
	Atten=2, effective measurement range of 150–1,750 mV	-40	40	mV
	Atten=3, effective measurement range of 150–2,450 mV	-60	60	mV

### 4.1.3 Hall Sensor

ESP32 integrates a Hall sensor based on an N-carrier resistor. When the chip is in the magnetic field, the Hall sensor develops a small voltage laterally on the resistor, which can be directly measured by the ADC.

### 4.1.4 Digital-to-Analog Converter (DAC)

Two 8-bit DAC channels can be used to convert two digital signals into two analog voltage signal outputs. The design structure is composed of integrated resistor strings and a buffer. This dual DAC supports power supply as input voltage reference. The two DAC channels can also support independent conversions.

### 4.1.5 Touch Sensor

ESP32 has 10 capacitive-sensing GPIOs, which detect variations induced by touching or approaching the GPIOs with a finger or other objects. The low-noise nature of the design and the high sensitivity of the circuit allow relatively small pads to be used. Arrays of pads can also be used, so that a larger area or more points can be detected. The 10 capacitive-sensing GPIOs are listed in Table 8.

**Table 8: Capacitive-Sensing GPIOs Available on ESP32**

Capacitive-sensing signal name	Pin name
T0	GPIO4
T1	GPIO0
T2	GPIO2
T3	MTDO
T4	MTCK
T5	MTD1
T6	MTMS
T7	GPIO27
T8	32K_XN
T9	32K_XP

### 4.1.6 Ultra-Lower-Power Co-processor

The ULP processor and RTC memory remain powered on during the Deep-sleep mode. Hence, the developer can store a program for the ULP processor in the RTC slow memory to access the peripheral devices, internal timers and internal sensors during the Deep-sleep mode. This is useful for designing applications where the CPU needs to be woken up by an external event, or a timer, or a combination of the two, while maintaining minimal power consumption.

### 4.1.7 Ethernet MAC Interface

An IEEE-802.3-2008-compliant Media Access Controller (MAC) is provided for Ethernet LAN communications. ESP32 requires an external physical interface device (PHY) to connect to the physical LAN bus (twisted-pair, fiber, etc.). The PHY is connected to ESP32 through 17 signals of MII or nine signals of RMII. The following features are supported on the Ethernet MAC (EMAC) interface:

- 10 Mbps and 100 Mbps rates
- Dedicated DMA controller allowing high-speed transfer between the dedicated SRAM and Ethernet MAC

- Tagged MAC frame (VLAN support)
- Half-duplex (CSMA/CD) and full-duplex operation
- MAC control sublayer (control frames)
- 32-bit CRC generation and removal
- Several address-filtering modes for physical and multicast address (multicast and group addresses)
- 32-bit status code for each transmitted or received frame
- Internal FIFOs to buffer transmit and receive frames. The transmit FIFO and the receive FIFO are both 512 words (32-bit)
- Hardware PTP (Precision Time Protocol) in accordance with IEEE 1588 2008 (PTP V2)
- 25 MHz/50 MHz clock output

#### 4.1.8 SD/SDIO/MMC Host Controller

An SD/SDIO/MMC host controller is available on ESP32, which supports the following features:

- Secure Digital memory (SD mem Version 3.0 and Version 3.01)
- Secure Digital I/O (SDIO Version 3.0)
- Consumer Electronics Advanced Transport Architecture (CE-ATA Version 1.1)
- Multimedia Cards (MMC Version 4.41, eMMC Version 4.5 and Version 4.51)

The controller allows up to 80 MHz of clock output in three different data-bus modes: 1-bit, 4-bit and 8-bit. It supports two SD/SDIO/MMC4.41 cards in a 4-bit data-bus mode. It also supports one SD card operating at 1.8V.

#### 4.1.9 SDIO/SPI Slave Controller

ESP32 integrates an SD device interface that conforms to the industry-standard SDIO Card Specification Version 2.0, and allows a host controller to access the SoC, using the SDIO bus interface and protocol. ESP32 acts as the slave on the SDIO bus. The host can access the SDIO-interface registers directly and can access shared memory via a DMA engine, thus maximizing performance without engaging the processor cores.

The SDIO/SPI slave controller supports the following features:

- SPI, 1-bit SDIO, and 4-bit SDIO transfer modes over the full clock range from 0 to 50 MHz
- Configurable sampling and driving clock edge
- Special registers for direct access by host
- Interrupts to host for initiating data transfer
- Automatic loading of SDIO bus data and automatic discarding of padding data
- Block size of up to 512 bytes
- Interrupt vectors between the host and the slave, allowing both to interrupt each other
- Supports DMA for data transfer

#### 4.1.10 Universal Asynchronous Receiver Transmitter (UART)

ESP32 has three UART interfaces, i.e., UART0, UART1 and UART2, which provide asynchronous communication (RS232 and RS485) and IrDA support, communicating at a speed of up to 5 Mbps. UART provides hardware management of the CTS and RTS signals and software flow control (XON and XOFF). All of the interfaces can be accessed by the DMA controller or directly by the CPU.

#### 4.1.11 I2C Interface

ESP32 has two I2C bus interfaces which can serve as I2C master or slave, depending on the user's configuration. The I2C interfaces support:

- Standard mode (100 kbit/s)
- Fast mode (400 kbit/s)
- Up to 5 MHz, yet constrained by SDA pull-up strength
- 7-bit/10-bit addressing mode
- Dual addressing mode

Users can program command registers to control I2C interfaces, so that they have more flexibility.

#### 4.1.12 I2S Interface

Two standard I2S interfaces are available in ESP32. They can be operated in master or slave mode, in full duplex and half-duplex communication modes, and can be configured to operate with an 8-/16-/32-/48-/64-bit resolution as input or output channels. BCK clock frequency, from 10 kHz up to 40 MHz, is supported. When one or both of the I2S interfaces are configured in the master mode, the master clock can be output to the external DAC/CODEC.

Both of the I2S interfaces have dedicated DMA controllers. PDM and BT PCM interfaces are supported.

#### 4.1.13 Infrared Remote Controller

The infrared remote controller supports eight channels of infrared remote transmission and receiving. By programming the pulse waveform, it supports various infrared protocols. Eight channels share a 512 x 32-bit block of memory to store the transmitting or receiving waveform.

#### 4.1.14 Pulse Counter

The pulse counter captures pulse and counts pulse edges through seven modes. It has eight channels, each of which captures four signals at a time. The four input signals include two pulse signals and two control signals. When the counter reaches a defined threshold, an interrupt is generated.

#### 4.1.15 Pulse Width Modulation (PWM)

The Pulse Width Modulation (PWM) controller can be used for driving digital motors and smart lights. The controller consists of PWM timers, the PWM operator and a dedicated capture sub-module. Each timer provides timing in synchronous or independent form, and each PWM operator generates a waveform for one PWM channel. The dedicated capture sub-module can accurately capture events with external timing.



#### 4.1.16 LED PWM

The LED PWM controller can generate 16 independent channels of digital waveforms with configurable periods and duties.

The 16 channels of digital waveforms operate with an APB clock of 80 MHz. Eight of these channels have the option of using the 8 MHz oscillator clock. Each channel can select a 20-bit timer with configurable counting range, while its accuracy of duty can be up to 16 bits within a 1 ms period.

The software can change the duty immediately. Moreover, each channel automatically supports step-by-step duty increase or decrease, which is useful for the LED RGB color-gradient generator.

#### 4.1.17 Serial Peripheral Interface (SPI)

ESP32 features three SPIs (SPI, HSPI and VSPI) in slave and master modes in 1-line full-duplex and 1/2/4-line half-duplex communication modes. These SPIs also support the following general-purpose SPI features:

- Four modes of SPI transfer format, which depend on the polarity (CPOL) and the phase (CPHA) of the SPI clock
- Up to 80 MHz (The actual speed it can reach depends on the selected pads, PCB tracing, peripheral characteristics, etc.)
- up to 64-byte FIFO

All SPIs can also be connected to the external flash/SRAM and LCD. Each SPI can be served by DMA controllers.

#### 4.1.18 Accelerator

ESP32 is equipped with hardware accelerators of general algorithms, such as AES (FIPS PUB 197), SHA (FIPS PUB 180-4), RSA, and ECC, which support independent arithmetic, such as Big Integer Multiplication and Big Integer Modular Multiplication. The maximum operation length for RSA, ECC, Big Integer Multiply and Big Integer Modular Multiplication is 4,096 bits.

The hardware accelerators greatly improve operation speed and reduce software complexity. They also support code encryption and dynamic decryption, which ensures that code in the flash will not be hacked.

## 4.2 Peripheral Pin Configurations

**Table 9: Peripheral Pin Configurations**

Interface	Signal	Pin	Function
ADC	ADC1_CH0	SENSOR_VP	Two 12-bit SAR ADCs
	ADC1_CH1	SENSOR_VN	
	ADC1_CH2	SENSOR_CAPP	
	ADC1_CH3	SENSOR_CAPN	
	ADC1_CH4	32K_XP	
	ADC1_CH5	32K_XN	
	ADC1_CH6	VDET_1	
	ADC1_CH7	VDET_2	
	ADC2_CH0	GPIO4	
	ADC2_CH1	GPIO0	
	ADC2_CH2	GPIO2	
	ADC2_CH3	MTDO	
	ADC2_CH4	MTCK	
	ADC2_CH5	MTDI	
	ADC2_CH6	MTMS	
	ADC2_CH7	GPIO27	
	ADC2_CH8	GPIO25	
	ADC2_CH9	GPIO26	
DAC	DAC_1	GPIO25	Two 8-bit DACs
	DAC_2	GPIO26	
Touch Sensor	TOUCH0	GPIO4	Capacitive touch sensors
	TOUCH1	GPIO0	
	TOUCH2	GPIO2	
	TOUCH3	MTDO	
	TOUCH4	MTCK	
	TOUCH5	MTDI	
	TOUCH6	MTMS	
	TOUCH7	GPIO27	
	TOUCH8	32K_XN	
	TOUCH9	32K_XP	
JTAG	MTDI	MTDI	JTAG for software debugging
	MTCK	MTCK	
	MTMS	MTMS	
	MTDO	MTDO	

Interface	Signal	Pin	Function
SD/SDIO/MMC Host Controller	HS2_CLK	MTMS	Supports SD memory card V3.01 standard
	HS2_CMD	MTDO	
	HS2_DATA0	GPIO2	
	HS2_DATA1	GPIO4	
	HS2_DATA2	MTDI	
	HS2_DATA3	MTCK	
Motor PWM	PWM0_OUT0~2	Any GPIO Pins	Three channels of 16-bit timers generate PWM waveforms. Each channel has a pair of output signals, three fault detection signals, three event-capture signals, and three sync signals.
	PWM1_OUT_IN0~2		
	PWM0_FLT_IN0~2		
	PWM1_FLT_IN0~2		
	PWM0_CAP_IN0~2		
	PWM1_CAP_IN0~2		
	PWM0_SYNC_IN0~2		
	PWM1_SYNC_IN0~2		
SDIO/SPI Slave Controller	SD_CLK	MTMS	SDIO interface that conforms to the industry standard SDIO 2.0 card specification
	SD_CMD	MTDO	
	SD_DATA0	GPIO2	
	SD_DATA1	GPIO4	
	SD_DATA2	MTDI	
	SD_DATA3	MTCK	
UART	U0RXD_in	Any GPIO Pins	Two UART devices with hardware flow-control and DMA
	U0CTS_in		
	U0DSR_in		
	U0TXD_out		
	U0RTS_out		
	U0DTR_out		
	U1RXD_in		
	U1CTS_in		
	U1TXD_out		
	U1RTS_out		
	U2RXD_in		
	U2CTS_in		
	U2TXD_out		
	U2RTS_out		
I2C	I2CEXT0_SCL_in	Any GPIO Pins	Two I2C devices in slave or master mode
	I2CEXT0_SDA_in		
	I2CEXT1_SCL_in		
	I2CEXT1_SDA_in		
	I2CEXT0_SCL_out		
	I2CEXT0_SDA_out		
	I2CEXT1_SCL_out		
	I2CEXT1_SDA_out		

Interface	Signal	Pin	Function
LED PWM	ledc_hs_sig_out0~7	Any GPIO Pins	16 independent channels @80 MHz clock/RTC CLK. Duty accuracy: 16 bits.
	ledc_ls_sig_out0~7		
I2S	I2S0I_DATA_in0~15	Any GPIO Pins	Stereo input and output from/to the audio codec; parallel LCD data output; parallel camera data input
	I2S0O_BCK_in		
	I2S0O_WS_in		
	I2S0I_BCK_in		
	I2S0I_WS_in		
	I2S0I_H_SYNC		
	I2S0I_V_SYNC		
	I2S0I_H_ENABLE		
	I2S0O_BCK_out		
	I2S0O_WS_out		
	I2S0I_BCK_out		
	I2S0I_WS_out		
	I2S0O_DATA_out0~23		
	I2S1I_DATA_in0~15		
	I2S1O_BCK_in		
	I2S1O_WS_in		
	I2S1I_BCK_in		
	I2S1I_WS_in		
	I2S1I_H_SYNC		
	I2S1I_V_SYNC		
	I2S1I_H_ENABLE		
	I2S1O_BCK_out		
I2S1O_WS_out			
I2S1I_BCK_out			
I2S1I_WS_out			
I2S1O_DATA_out0~23			
Infrared Remote Controller	RMT_SIG_IN0~7	Any GPIO Pins	Eight channels for an IR transmitter and receiver of various waveforms
	RMT_SIG_OUT0~7		
General Purpose SPI	HSPIQ_in/_out	Any GPIO Pins	Standard SPI consists of clock, chip-select, MOSI and MISO. These SPIs can be connected to LCD and other external devices. They support the following features: <ul style="list-style-type: none"> <li>• both master and slave modes;</li> <li>• 4 sub-modes of the SPI transfer format;</li> <li>• configurable SPI frequency;</li> <li>• up to 64 bytes of FIFO and DMA.</li> </ul>
	HSPID_in/_out		
	HSPICLK_in/_out		
	HSPI_CS0_in/_out		
	HSPI_CS1_out		
	HSPI_CS2_out		
	VSPIQ_in/_out		
	VSPID_in/_out		
	VSPICLK_in/_out		
	VSPI_CS0_in/_out		
	VSPI_CS1_out		
	VSPI_CS2_out		

Interface	Signal	Pin	Function
Parallel QSPI	SPIHD	SD_DATA_2	Supports Standard SPI, Dual SPI, and Quad SPI that can be connected to the external flash and SRAM
	SPIWP	SD_DATA_3	
	SPICS0	SD_CMD	
	SPICLK	SD_CLK	
	SPIQ	SD_DATA_0	
	SPID	SD_DATA_1	
	HSPICLK	MTMS	
	HSPICS0	MTD0	
	HSPIQ	MTDI	
	HSPID	MTCK	
	HSPIHD	GPIO4	
	HSPiWP	GPIO2	
	VSPICLK	GPIO18	
	VSPICS0	GPIO5	
	VSPIQ	GPIO19	
	VSPID	GPIO23	
VSPiHD	GPIO21		
VSPiWP	GPIO22		
EMAC	EMAC_TX_CLK	GPIO0	Ethernet MAC with MII/RMII interface
	EMAC_RX_CLK	GPIO5	
	EMAC_TX_EN	GPIO21	
	EMAC_TXD0	GPIO19	
	EMAC_TXD1	GPIO22	
	EMAC_TXD2	MTMS	
	EMAC_TXD3	MTDI	
	EMAC_RX_ER	MTCK	
	EMAC_RX_DV	GPIO27	
	EMAC_RXD0	GPIO25	
	EMAC_RXD1	GPIO26	
	EMAC_RXD2	U0TXD	
	EMAC_RXD3	MTD0	
	EMAC_CLK_OUT	GPIO16	
	EMAC_CLK_OUT_180	GPIO17	
	EMAC_TX_ER	GPIO4	
	EMAC_MDC_out	Any GPIO Pins	
	EMAC_MDI_in	Any GPIO Pins	
	EMAC_MDO_out	Any GPIO Pins	
	EMAC_CRS_out	Any GPIO Pins	
EMAC_COL_out	Any GPIO Pins		

Interface	Signal	Pin	Function
Pulse Counter	pcnt_sig_ch0_in0	Any GPIO Pins	Operating in seven different modes, the pulse counter captures pulse and counts pulse edges.
	pcnt_sig_ch1_in0		
	pcnt_ctrl_ch0_in0		
	pcnt_ctrl_ch1_in0		
	pcnt_sig_ch0_in1		
	pcnt_sig_ch1_in1		
	pcnt_ctrl_ch0_in1		
	pcnt_ctrl_ch1_in1		
	pcnt_sig_ch0_in2		
	pcnt_sig_ch1_in2		
	pcnt_ctrl_ch0_in2		
	pcnt_ctrl_ch1_in2		
	pcnt_sig_ch0_in3		
	pcnt_sig_ch1_in3		
	pcnt_ctrl_ch0_in3		
	pcnt_ctrl_ch1_in3		
	pcnt_sig_ch0_in4		
	pcnt_sig_ch1_in4		
	pcnt_ctrl_ch0_in4		
	pcnt_ctrl_ch1_in4		
	pcnt_sig_ch0_in5		
	pcnt_sig_ch1_in5		
	pcnt_ctrl_ch0_in5		
	pcnt_ctrl_ch1_in5		
	pcnt_sig_ch0_in6		
	pcnt_sig_ch1_in6		
	pcnt_ctrl_ch0_in6		
	pcnt_ctrl_ch1_in6		
pcnt_sig_ch0_in7			
pcnt_sig_ch1_in7			
pcnt_ctrl_ch0_in7			
pcnt_ctrl_ch1_in7			

## 5. Electrical Characteristics

### 5.1 Absolute Maximum Ratings

Stresses beyond the absolute maximum ratings listed in the table below may cause permanent damage to the device. These are stress ratings only, and do not refer to the functional operation of the device.

**Table 10: Absolute Maximum Ratings**

Symbol	Parameter	Min	Max	Unit
VDDA, VDD3P3, VDD3P3_RTC, VDD3P3_CPU, VDD_SDIO	-	-0.3	3.6	V
$T_{store}$	Storage temperature	-40	150	°C

### 5.2 Recommended Operating Conditions

**Table 11: Recommended Operating Conditions**

Symbol	Parameter	Min	Typical	Max	Unit
VDDA, VDD3P3, VDD3P3_RTC <sup>1</sup> , VDD_SDIO (3.3V mode) <sup>2</sup>	-	2.3	3.3	3.6	V
VDD3P3_CPU	-	1.8	3.3	3.6	V
$I_{VDD}$	Current delivered by external power supply	0.5	-	-	A
$T^3$	Operating temperature	-40	-	125	°C

- When writing eFuse, VDD3P3\_RTC should be at least 3.3V.
- VDD\_SDIO works as the power supply for the related IO, and also for an external device. Please refer to the Appendix [IO\\_MUX](#) of this datasheet for more details.
  - VDD\_SDIO can be sourced internally by the ESP32 from the VDD3P3\_RTC power domain:
    - When VDD\_SDIO operates at 3.3V, it is driven directly by VDD3P3\_RTC through a 6Ω resistor, therefore, there will be some voltage drop from VDD3P3\_RTC.
    - When VDD\_SDIO operates at 1.8V, it can be generated from ESP32's internal LDO. The maximum current this LDO can offer is 40 mA, and the output voltage range is 1.65 ~ 2.0V.
  - VDD\_SDIO can also be driven by an external power supply.
  - Please refer to Power Scheme, section 2.3, for more information.
- The operating temperature of ESP32-D2WD ranges from -40°C ~ 105°C, due to the flash embedded in it. The other chips in this series have no embedded flash, so their range of operating temperatures is -40°C ~ 125°C.

### 5.3 DC Characteristics (3.3V, 25°C)

**Table 12: DC Characteristics**

Symbol	Parameter	Min	Typ	Max	Unit
$C_{IN}$	Pin capacitance	-	2	-	pF
$V_{IH}$	High-level input voltage	$0.75 \times VDD^1$	-	$VDD + 0.3$	V
$V_{IL}$	Low-level input voltage	-0.3	-	$0.25 \times VDD$	V
$I_{IH}$	High-level input current	-	-	50	nA

Symbol	Parameter	Min	Typ	Max	Unit
$I_{IL}$	Low-level input current	-	-	50	nA
$V_{OH}$	High-level output voltage	$0.8 \times V_{DD}$	-	-	V
$V_{OL}$	Low-level output voltage	-	-	$0.1 \times V_{DD}$	V
$I_{OH}$	High-level source current ( $V_{DD} = 3.3V$ , $V_{OH} = 2.64V$ , $PAD\_DRIVER = 3$ )	-	40	-	mA
$I_{OL}$	Low-level sink current ( $V_{DD} = 3.3V$ , $V_{OL} = 0.495V$ , $PAD\_DRIVER = 3$ )	-	28	-	mA
$R_{PU}$	Pull-up resistor	-	45	-	k $\Omega$
$R_{PD}$	Pull-down resistor	-	45	-	k $\Omega$
$V_{IL\_nRST}$	Low-level input voltage of CHIP_PU to reset the chip	-	-	0.6	V

1. VDD is the I/O voltage for a particular power domain of pins. More details can be found in [IO\\_MUX](#) of this datasheet.

## 5.4 Reliability Qualifications

**Table 13: Reliability Qualifications**

Reliability tests	Standards	Test conditions	Result
Electro-Static Discharge Sensitivity (ESD), Charge Device Mode (CDM) <sup>1</sup>	JEDEC EIA/JESD22-C101	$\pm 500V$ , all pins	Pass
Electro-Static Discharge Sensitivity (ESD), Human Body Mode (HBM) <sup>2</sup>	JEDEC EIA/JESD22-A114	$\pm 1500V$ , all pins	Pass
Latch-up (Over-current test)	JEDEC STANDARD NO.78	$\pm 50$ mA ~ $\pm 200$ mA, room temperature, test for IO	Pass
Latch-up (Over-voltage test)	JEDEC STANDARD NO.78	$1.5 \times V_{max}$ , room temperature, test for $V_{supply}$	Pass
Moisture Sensitivity Level (MSL)	J-STD-020, MSL 3	$30^{\circ}C$ , 60% RH, 192 hours, IR x 3 @ $260^{\circ}C$	Pass

1. JEDEC document JEP157 states that 250V CDM allows safe manufacturing with a standard ESD control process.

2. JEDEC document JEP155 states that 500V HBM allows safe manufacturing with a standard ESD control process.

## 5.5 RF Power-Consumption Specifications

The power consumption measurements are taken with a 3.3V supply at  $25^{\circ}C$  of ambient temperature at the RF port. All transmitters' measurements are based on a 50% duty cycle.

**Table 14: RF Power-Consumption Specifications**

Mode	Min	Typ	Max	Unit
Transmit 802.11b, DSSS 1 Mbps, POUT = +19.5 dBm	-	240	-	mA
Transmit 802.11b, OFDM 54 Mbps, POUT = +16 dBm	-	190	-	mA
Transmit 802.11g, OFDM MCS7, POUT = +14 dBm	-	180	-	mA



Mode	Min	Typ	Max	Unit
Receive 802.11b/g/n	-	95 ~ 100	-	mA
Transmit BT/BLE, POUT = 0 dBm	-	130	-	mA
Receive BT/BLE	-	95 ~ 100	-	mA

## 5.6 Wi-Fi Radio

Table 15: Wi-Fi Radio Characteristics

Description	Min	Typical	Max	Unit
Input frequency	2412	-	2484	MHz
Output impedance*	-	*	-	$\Omega$
Tx power				
Output power of PA for 72.2 Mbps	13	14	15	dBm
Output power of PA for 11b mode	19.5	20	20.5	dBm
Sensitivity				
DSSS, 1 Mbps	-	-98	-	dBm
CCK, 11 Mbps	-	-91	-	dBm
OFDM, 6 Mbps	-	-93	-	dBm
OFDM, 54 Mbps	-	-75	-	dBm
HT20, MCS0	-	-93	-	dBm
HT20, MCS7	-	-73	-	dBm
HT40, MCS0	-	-90	-	dBm
HT40, MCS7	-	-70	-	dBm
MCS32	-	-89	-	dBm
Adjacent channel rejection				
OFDM, 6 Mbps	-	37	-	dB
OFDM, 54 Mbps	-	21	-	dB
HT20, MCS0	-	37	-	dB
HT20, MCS7	-	20	-	dB

\*The typical value of ESP32's Wi-Fi radio output impedance is different in chips of different QFN packages. For ESP32 chips with a QFN 6x6 package (ESP32-D0WDQ6), the value is 30+j10  $\Omega$ . For ESP32 chips with a QFN 5x5 package (ESP32-D0WD, ESP32-D2WD, ESP32-S0WD), the value is 35+j10  $\Omega$ .

## 5.7 Bluetooth Radio

### 5.7.1 Receiver – Basic Data Rate

Table 16: Receiver Characteristics – Basic Data Rate

Parameter	Conditions	Min	Typ	Max	Unit
Sensitivity @0.1% BER	-	-	-94	-	dBm
Maximum received signal @0.1% BER	-	0	-	-	dBm
Co-channel C/I	-	-	+7	-	dB

Parameter	Conditions	Min	Typ	Max	Unit
Adjacent channel selectivity C/I	F = F0 + 1 MHz	-	-	-6	dB
	F = F0 - 1 MHz	-	-	-6	dB
	F = F0 + 2 MHz	-	-	-25	dB
	F = F0 - 2 MHz	-	-	-33	dB
	F = F0 + 3 MHz	-	-	-25	dB
	F = F0 - 3 MHz	-	-	-45	dB
Out-of-band blocking performance	30 MHz ~ 2000 MHz	-10	-	-	dBm
	2000 MHz ~ 2400 MHz	-27	-	-	dBm
	2500 MHz ~ 3000 MHz	-27	-	-	dBm
	3000 MHz ~ 12.5 GHz	-10	-	-	dBm
Intermodulation	-	-36	-	-	dBm

### 5.7.2 Transmitter – Basic Data Rate

Table 17: Transmitter Characteristics – Basic Data Rate

Parameter	Conditions	Min	Typ	Max	Unit
RF transmit power	-	-	0	-	dBm
Gain control step	-	-	3	-	dBm
RF power control range	-	-12	-	+12	dBm
+20 dB bandwidth	-	-	0.9	-	MHz
Adjacent channel transmit power	F = F0 ± 2 MHz	-	-47	-	dBm
	F = F0 ± 3 MHz	-	-55	-	dBm
	F = F0 ± > 3 MHz	-	-60	-	dBm
$\Delta f_{1avg}$	-	-	-	155	kHz
$\Delta f_{2max}$	-	133.7	-	-	kHz
$\Delta f_{2avg}/\Delta f_{1avg}$	-	-	0.92	-	-
ICFT	-	-	-7	-	kHz
Drift rate	-	-	0.7	-	kHz/50 $\mu$ s
Drift (DH1)	-	-	6	-	kHz
Drift (DH5)	-	-	6	-	kHz

### 5.7.3 Receiver – Enhanced Data Rate

Table 18: Receiver Characteristics – Enhanced Data Rate

Parameter	Conditions	Min	Typ	Max	Unit
$\pi/4$ DQPSK					
Sensitivity @0.01% BER	-	-	-90	-	dBm
Maximum received signal @0.01% BER	-	-	0	-	dBm
Co-channel C/I	-	-	11	-	dB
Adjacent channel selectivity C/I	F = F0 + 1 MHz	-	-7	-	dB
	F = F0 - 1 MHz	-	-7	-	dB
	F = F0 + 2 MHz	-	-25	-	dB
	F = F0 - 2 MHz	-	-35	-	dB
	F = F0 + 3 MHz	-	-25	-	dB

Parameter	Conditions	Min	Typ	Max	Unit
	$F = F_0 - 3 \text{ MHz}$	-	-45	-	dB
8DPSK					
Sensitivity @0.01% BER	-	-	-84	-	dBm
Maximum received signal @0.01% BER	-	-	-5	-	dBm
C/I c-channel	-	-	18	-	dB
Adjacent channel selectivity C/I	$F = F_0 + 1 \text{ MHz}$	-	2	-	dB
	$F = F_0 - 1 \text{ MHz}$	-	2	-	dB
	$F = F_0 + 2 \text{ MHz}$	-	-25	-	dB
	$F = F_0 - 2 \text{ MHz}$	-	-25	-	dB
	$F = F_0 + 3 \text{ MHz}$	-	-25	-	dB
	$F = F_0 - 3 \text{ MHz}$	-	-38	-	dB

### 5.7.4 Transmitter – Enhanced Data Rate

Table 19: Transmitter Characteristics – Enhanced Data Rate

Parameter	Conditions	Min	Typ	Max	Unit
RF transmit power	-	-	0	-	dBm
Gain control step	-	-	3	-	dBm
RF power control range	-	-12	-	+12	dBm
$\pi/4$ DQPSK max $w_0$	-	-	-0.72	-	kHz
$\pi/4$ DQPSK max $w_i$	-	-	-6	-	kHz
$\pi/4$ DQPSK max $ w_i + w_0 $	-	-	-7.42	-	kHz
8DPSK max $w_0$	-	-	0.7	-	kHz
8DPSK max $w_i$	-	-	-9.6	-	kHz
8DPSK max $ w_i + w_0 $	-	-	-10	-	kHz
$\pi/4$ DQPSK modulation accuracy	RMS DEVM	-	4.28	-	%
	99% DEVM	-	100	-	%
	Peak DEVM	-	13.3	-	%
8 DPSK modulation accuracy	RMS DEVM	-	5.8	-	%
	99% DEVM	-	100	-	%
	Peak DEVM	-	14	-	%
In-band spurious emissions	$F = F_0 \pm 1 \text{ MHz}$	-	-46	-	dBm
	$F = F_0 \pm 2 \text{ MHz}$	-	-40	-	dBm
	$F = F_0 \pm 3 \text{ MHz}$	-	-46	-	dBm
	$F = F_0 \pm > 3 \text{ MHz}$	-	-	-53	dBm
EDR differential phase coding	-	-	100	-	%

## 5.8 Bluetooth LE Radio

### 5.8.1 Receiver

Table 20: Receiver Characteristics – BLE

Parameter	Conditions	Min	Typ	Max	Unit
Sensitivity @30.8% PER	-	-	-97	-	dBm
Maximum received signal @30.8% PER	-	0	-	-	dBm
Co-channel C/I	-	-	+10	-	dB
Adjacent channel selectivity C/I	$F = F_0 + 1 \text{ MHz}$	-	-5	-	dB
	$F = F_0 - 1 \text{ MHz}$	-	-5	-	dB
	$F = F_0 + 2 \text{ MHz}$	-	-25	-	dB
	$F = F_0 - 2 \text{ MHz}$	-	-35	-	dB
	$F = F_0 + 3 \text{ MHz}$	-	-25	-	dB
	$F = F_0 - 3 \text{ MHz}$	-	-45	-	dB
Out-of-band blocking performance	30 MHz ~ 2000 MHz	-10	-	-	dBm
	2000 MHz ~ 2400 MHz	-27	-	-	dBm
	2500 MHz ~ 3000 MHz	-27	-	-	dBm
	3000 MHz ~ 12.5 GHz	-10	-	-	dBm
Intermodulation	-	-36	-	-	dBm

### 5.8.2 Transmitter

Table 21: Transmitter Characteristics – BLE

Parameter	Conditions	Min	Typ	Max	Unit
RF transmit power	-	-	0	-	dBm
Gain control step	-	-	3	-	dBm
RF power control range	-	-12	-	+12	dBm
Adjacent channel transmit power	$F = F_0 \pm 2 \text{ MHz}$	-	-52	-	dBm
	$F = F_0 \pm 3 \text{ MHz}$	-	-58	-	dBm
	$F = F_0 \pm > 3 \text{ MHz}$	-	-60	-	dBm
$\Delta f_{1avg}$	-	-	-	265	kHz
$\Delta f_{2max}$	-	247	-	-	kHz
$\Delta f_{2avg}/\Delta f_{1avg}$	-	-	-0.92	-	-
ICFT	-	-	-10	-	kHz
Drift rate	-	-	0.7	-	kHz/50 $\mu$ s
Drift	-	-	2	-	kHz

## 6. Package Information

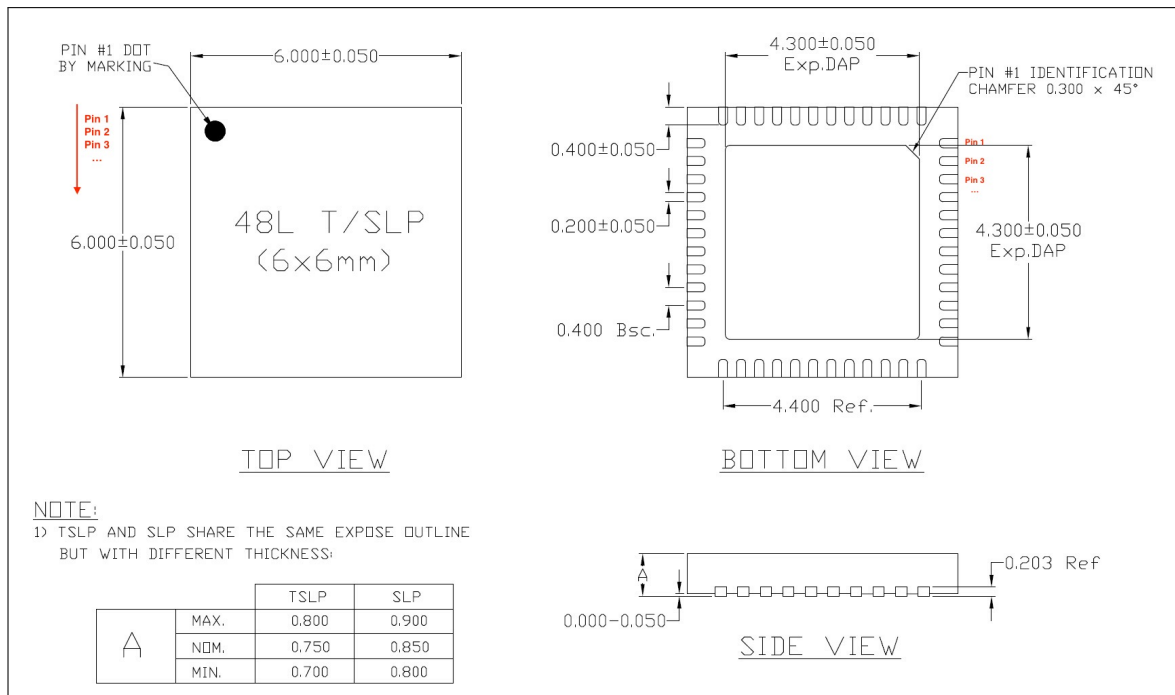

Figure 7: QFN48 (6x6 mm) Package

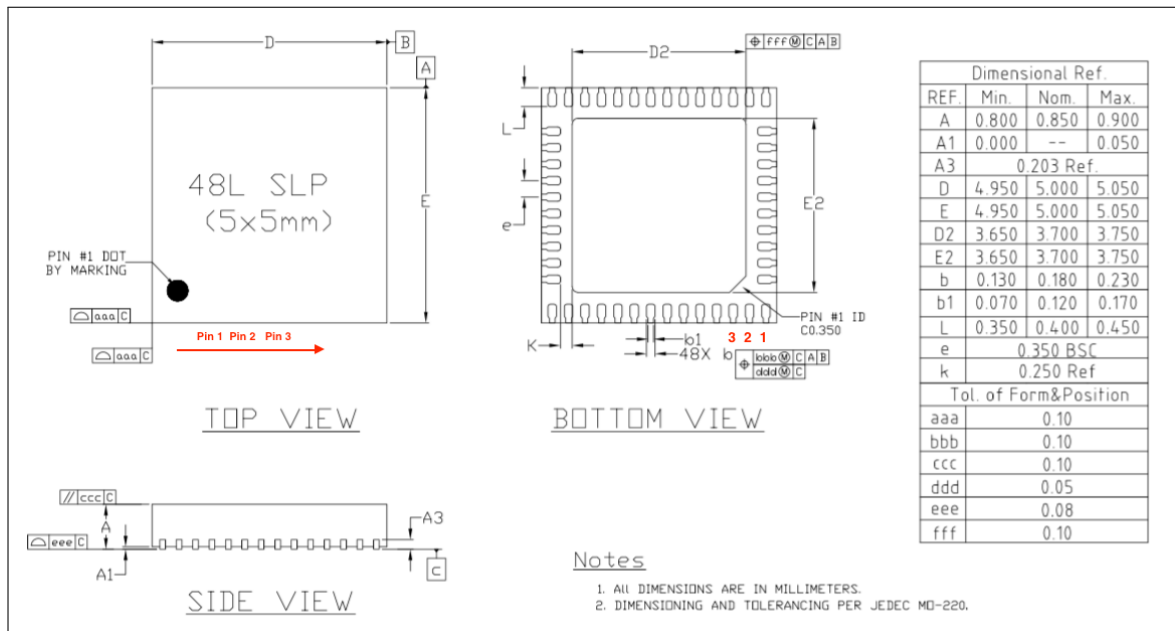
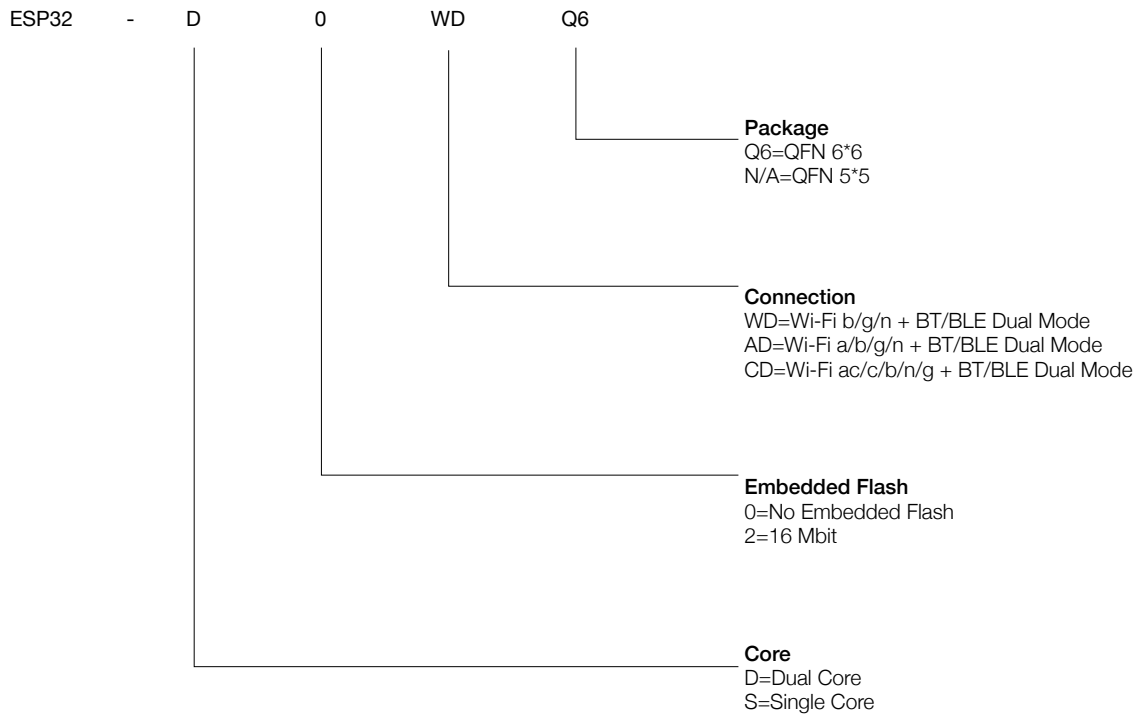

Figure 8: QFN48 (5x5 mm) Package

**Note:**

The pins of the chip are numbered in an anti-clockwise direction from Pin 1 in the top view.

## 7. Part Number and Ordering Information



**Figure 9: ESP32 Part Number**

The table below provides the ordering information of the ESP32 series of chips.

**Table 22: ESP32 Ordering Information**

Ordering code	Core	Embedded flash	Connection	Package
ESP32-D0WDQ6	Dual core	No embedded flash	Wi-Fi b/g/n + BT/BLE Dual Mode	QFN 6*6
ESP32-D0WD	Dual core	No embedded flash	Wi-Fi b/g/n + BT/BLE Dual Mode	QFN 5*5
ESP32-D2WD	Dual core	16-Mbit embedded flash (40 MHz)	Wi-Fi b/g/n + BT/BLE Dual Mode	QFN 5*5
ESP32-S0WD	Single core	No embedded flash	Wi-Fi b/g/n + BT/BLE Dual Mode	QFN 5*5

## 8. Learning Resources

### 8.1 Must-Read Documents

Click on the following links to access documents related to ESP32.

- [ESP-IDF Programming Guide](#)  
It hosts extensive documentation for ESP-IDF, ranging from hardware guides to API reference.
- [ESP32 Technical Reference Manual](#)  
The manual provides detailed information on how to use the ESP32 memory and peripherals.
- [ESP32 Hardware Resources](#)  
The zip files include schematics, PCB layout, Gerber and BOM list.
- [ESP32 Hardware Design Guidelines](#)  
The guidelines provide recommended design practices when developing standalone or add-on systems based on the ESP32 series of products, including the ESP32 chip, the ESP32 modules and development boards.
- [ESP32 AT Instruction Set and Examples](#)  
This document introduces the ESP32 AT commands, explains how to use them, and provides examples of several common AT commands.
- [Espressif Products Ordering Information](#)

### 8.2 Must-Have Resources

Here are the ESP32-related must-have resources.

- [ESP32 BBS](#)  
This is an Engineer-to-Engineer (E2E) Community for ESP32, where you can post questions, share knowledge, explore ideas, and solve problems together with fellow engineers.
- [ESP32 GitHub](#)  
ESP32 development projects are freely distributed under Espressif's MIT license on GitHub. This channel of communication has been established to help developers get started with ESP32 and encourage them to share their knowledge of ESP32-related hardware and software.
- [ESP32 Tools](#)  
This is a webpage where users can download ESP32 Flash Download Tools and the zip file "ESP32 Certification and Test".
- [ESP-IDF](#)  
This webpage links users to the official IoT development framework for ESP32.
- [ESP32 Resources](#)  
This webpage provides the links to all available ESP32 documents, SDK and tools.

## Appendix A – ESP32 Pin Lists

### A.1. Notes on ESP32 Pin Lists

Table 23: Notes on ESP32 Pin Lists

No.	Description
1	In Table <a href="#">IO_MUX</a> , the boxes highlighted in yellow indicate the GPIO pins that are input-only. Please see the following note for further details.
2	GPIO pins 34-39 are input-only. These pins do not feature an output driver or internal pull-up/pull-down circuitry. The pin names are: SENSOR_VP (GPIO36), SENSOR_CAPP (GPIO37), SENSOR_CAPN (GPIO38), SENSOR_VN (GPIO39), VDET_1 (GPIO34), VDET_2 (GPIO35).
3	The pins are grouped into four power domains: VANA (analog power supply), VRTC (RTC power supply), VIO (power supply of digital IOs and CPU cores), VSDIO (power supply of SDIO IOs). VSDIO is the output of the internal SDIO-LDO. The voltage of SDIO-LDO can be configured at 1.8V or be the same as that of VRTC. The strapping pin and eFuse bits determine the default voltage of the SDIO-LDO. Software can change the voltage of the SDIO-LDO by configuring register bits. For details, please see the column “Power Domain” in Table <a href="#">IO_MUX</a> .
4	The functional pins in the VRTC domain are those with analog functions, including the 32 kHz crystal oscillator, ADC, DAC, and the capacitive touch sensor. Please see columns “Analog Function 1~3” in Table <a href="#">IO_MUX</a> .
5	These VRTC pins support the RTC function, and can work during Deep-sleep. For example, an RTC-GPIO can be used for waking up the chip from Deep-sleep.
6	The GPIO pins support up to six digital functions, as shown in columns “Function 1~6” In Table <a href="#">IO_MUX</a> . The function selection registers will be set as “ $N-1$ ”, where $N$ is the function number. Below are some definitions: <ul style="list-style-type: none"> <li>• SD_* is for signals of the SDIO slave.</li> <li>• HS1_* is for Port 1 signals of the SDIO host.</li> <li>• HS2_* is for Port 2 signals of the SDIO host.</li> <li>• MT* is for signals of the JTAG.</li> <li>• U0* is for signals of the UART0 module.</li> <li>• U1* is for signals of the UART1 module.</li> <li>• U2* is for signals of the UART2 module.</li> <li>• SPI* is for signals of the SPI01 module.</li> <li>• HSPI* is for signals of the SPI2 module.</li> <li>• VSPI* is for signals of the SPI3 module.</li> </ul>



No.	Description
7	<p>Each column about digital “Function” is accompanied by a column about “Type”. Please see the following explanations for the meanings of “type” with respect to each “function” they are associated with. For each “Function-<i>N</i>”, “type” signifies:</p> <ul style="list-style-type: none"> <li>• I: input only. If a function other than “Function-<i>N</i>” is assigned, the input signal of “Function-<i>N</i>” is still from this pin.</li> <li>• I1: input only. If a function other than “Function-<i>N</i>” is assigned, the input signal of “Function-<i>N</i>” is always “1”.</li> <li>• IO: input only. If a function other than “Function-<i>N</i>” is assigned, the input signal of “Function-<i>N</i>” is always “0”.</li> <li>• O: output only.</li> <li>• T: high-impedance.</li> <li>• I/O/T: combinations of input, output, and high-impedance according to the function signal.</li> <li>• I1/O/T: combinations of input, output, and high-impedance, according to the function signal. If a function is not selected, the input signal of the function is “1”.</li> </ul> <p>For example, pin 30 can function as HS1_CMD or SD_CMD, where HS1_CMD is of an “I1/O/T” type. If pin 30 is selected as HS1_CMD, this pin’s input and output are controlled by the SDIO host. If pin 30 is not selected as HS1_CMD, the input signal of the SDIO host is always “1”.</p>
8	<p>Each digital output pin is associated with its configurable drive strength. Column “Drive Strength” in Table <a href="#">IO_MUX</a> lists the default values. The drive strength of the digital output pins can be configured into one of the following four options:</p> <ul style="list-style-type: none"> <li>• 0: ~5 mA</li> <li>• 1: ~10 mA</li> <li>• 2: ~20 mA</li> <li>• 3: ~40 mA</li> </ul> <p>The default value is 2. The drive strength of the internal pull-up (wpu) and pull-down (wpd) is ~75 <math>\mu</math>A.</p>
9	<p>Column “At Reset” in Table <a href="#">IO_MUX</a> lists the status of each pin during reset, including input-enable (ie=1), internal pull-up (wpu) and internal pull-down (wpd). During reset, all pins are output-disabled.</p>
10	<p>Column “After Reset” in Table <a href="#">IO_MUX</a> lists the status of each pin immediately after reset, including input-enable (ie=1), internal pull-up (wpu) and internal pull-down (wpd). After reset, each pin is set to “Function 1”. The output-enable is controlled by digital Function 1.</p>
11	<p>Table <a href="#">Ethernet_MAC</a> is about the signal mapping inside Ethernet MAC. The Ethernet MAC supports MII and RMII interfaces, and supports both the internal PLL clock and the external clock source. For the MII interface, the Ethernet MAC is with/without the TX_ERR signal. MDC, MDIO, CRS and COL are slow signals, and can be mapped onto any GPIO pin through the GPIO-Matrix.</p>
12	<p>Table <a href="#">GPIO Matrix</a> is for the GPIO-Matrix. The signals of the on-chip functional modules can be mapped onto any GPIO pin. Some signals can be mapped onto a pin by both IO-MUX and GPIO-Matrix, as shown in the column tagged as “Same input signal from IO_MUX core” in Table <a href="#">GPIO Matrix</a>.</p>

No.	Description
13	*In Table <a href="#">GPIO_Matrix</a> the column “Default Value if unassigned” records the default value of the an input signal if no GPIO is assigned to it. The actual value is determined by register GPIO_FUNC $m$ _IN_INV_SEL and GPIO_FUNC $m$ _IN_SEL. (The value of $m$ ranges from 1 to 255.)

## A.2. GPIO\_Matrix

Table 24: GPIO\_Matrix

Signal No.	Input signals	Default value if unassigned*	Same input signal from IO_MUX core	Output signals	Output enable of output signals
0	SPICLK_in	0	yes	SPICLK_out	SPICLK_oe
1	SPIQ_in	0	yes	SPIQ_out	SPIQ_oe
2	SPID_in	0	yes	SPID_out	SPID_oe
3	SPIHD_in	0	yes	SPIHD_out	SPIHD_oe
4	SPIWP_in	0	yes	SPIWP_out	SPIWP_oe
5	SPICS0_in	0	yes	SPICS0_out	SPICS0_oe
6	SPICS1_in	0	no	SPICS1_out	SPICS1_oe
7	SPICS2_in	0	no	SPICS2_out	SPICS2_oe
8	HSPICLK_in	0	yes	HSPICLK_out	HSPICLK_oe
9	HSPIQ_in	0	yes	HSPIQ_out	HSPIQ_oe
10	HSPID_in	0	yes	HSPID_out	HSPID_oe
11	HSPICS0_in	0	yes	HSPICS0_out	HSPICS0_oe
12	HSPIHD_in	0	yes	HSPIHD_out	HSPIHD_oe
13	HSPIWP_in	0	yes	HSPIWP_out	HSPIWP_oe
14	U0RXD_in	0	yes	U0TXD_out	1'd1
15	U0CTS_in	0	yes	U0RTS_out	1'd1
16	U0DSR_in	0	no	U0DTR_out	1'd1
17	U1RXD_in	0	yes	U1TXD_out	1'd1
18	U1CTS_in	0	yes	U1RTS_out	1'd1
23	I2S0O_BCK_in	0	no	I2S0O_BCK_out	1'd1
24	I2S1O_BCK_in	0	no	I2S1O_BCK_out	1'd1
25	I2S0O_WS_in	0	no	I2S0O_WS_out	1'd1
26	I2S1O_WS_in	0	no	I2S1O_WS_out	1'd1
27	I2S0I_BCK_in	0	no	I2S0I_BCK_out	1'd1
28	I2S0I_WS_in	0	no	I2S0I_WS_out	1'd1
29	I2CEXT0_SCL_in	1	no	I2CEXT0_SCL_out	1'd1
30	I2CEXT0_SDA_in	1	no	I2CEXT0_SDA_out	1'd1
31	pwm0_sync0_in	0	no	sdio_tohost_int_out	1'd1
32	pwm0_sync1_in	0	no	pwm0_out0a	1'd1
33	pwm0_sync2_in	0	no	pwm0_out0b	1'd1
34	pwm0_f0_in	0	no	pwm0_out1a	1'd1
35	pwm0_f1_in	0	no	pwm0_out1b	1'd1
36	pwm0_f2_in	0	no	pwm0_out2a	1'd1
37	-	0	no	pwm0_out2b	1'd1
39	pcnt_sig_ch0_in0	0	no	-	1'd1
40	pcnt_sig_ch1_in0	0	no	-	1'd1
41	pcnt_ctrl_ch0_in0	0	no	-	1'd1
42	pcnt_ctrl_ch1_in0	0	no	-	1'd1

Signal No.	Input signals	Default value if unassigned	Same input signal from IO_MUX core	Output signals	Output enable of output signals
43	pcnt_sig_ch0_in1	0	no	-	1'd1
44	pcnt_sig_ch1_in1	0	no	-	1'd1
45	pcnt_ctrl_ch0_in1	0	no	-	1'd1
46	pcnt_ctrl_ch1_in1	0	no	-	1'd1
47	pcnt_sig_ch0_in2	0	no	-	1'd1
48	pcnt_sig_ch1_in2	0	no	-	1'd1
49	pcnt_ctrl_ch0_in2	0	no	-	1'd1
50	pcnt_ctrl_ch1_in2	0	no	-	1'd1
51	pcnt_sig_ch0_in3	0	no	-	1'd1
52	pcnt_sig_ch1_in3	0	no	-	1'd1
53	pcnt_ctrl_ch0_in3	0	no	-	1'd1
54	pcnt_ctrl_ch1_in3	0	no	-	1'd1
55	pcnt_sig_ch0_in4	0	no	-	1'd1
56	pcnt_sig_ch1_in4	0	no	-	1'd1
57	pcnt_ctrl_ch0_in4	0	no	-	1'd1
58	pcnt_ctrl_ch1_in4	0	no	-	1'd1
61	HSPICS1_in	0	no	HSPICS1_out	HSPICS1_oe
62	HSPICS2_in	0	no	HSPICS2_out	HSPICS2_oe
63	VSPICLK_in	0	yes	VSPICLK_out_mux	VSPICLK_oe
64	VSPIQ_in	0	yes	VSPIQ_out	VSPIQ_oe
65	VSPID_in	0	yes	VSPID_out	VSPID_oe
66	VSPIHD_in	0	yes	VSPIHD_out	VSPIHD_oe
67	VSPIWP_in	0	yes	VSPIWP_out	VSPIWP_oe
68	VSPICS0_in	0	yes	VSPICS0_out	VSPICS0_oe
69	VSPICS1_in	0	no	VSPICS1_out	VSPICS1_oe
70	VSPICS2_in	0	no	VSPICS2_out	VSPICS2_oe
71	pcnt_sig_ch0_in5	0	no	ledc_hs_sig_out0	1'd1
72	pcnt_sig_ch1_in5	0	no	ledc_hs_sig_out1	1'd1
73	pcnt_ctrl_ch0_in5	0	no	ledc_hs_sig_out2	1'd1
74	pcnt_ctrl_ch1_in5	0	no	ledc_hs_sig_out3	1'd1
75	pcnt_sig_ch0_in6	0	no	ledc_hs_sig_out4	1'd1
76	pcnt_sig_ch1_in6	0	no	ledc_hs_sig_out5	1'd1
77	pcnt_ctrl_ch0_in6	0	no	ledc_hs_sig_out6	1'd1
78	pcnt_ctrl_ch1_in6	0	no	ledc_hs_sig_out7	1'd1
79	pcnt_sig_ch0_in7	0	no	ledc_ls_sig_out0	1'd1
80	pcnt_sig_ch1_in7	0	no	ledc_ls_sig_out1	1'd1
81	pcnt_ctrl_ch0_in7	0	no	ledc_ls_sig_out2	1'd1
82	pcnt_ctrl_ch1_in7	0	no	ledc_ls_sig_out3	1'd1
83	rmt_sig_in0	0	no	ledc_ls_sig_out4	1'd1
84	rmt_sig_in1	0	no	ledc_ls_sig_out5	1'd1
85	rmt_sig_in2	0	no	ledc_ls_sig_out6	1'd1

Signal No.	Input signals	Default value if unassigned	Same input signal from IO_MUX core	Output signals	Output enable of output signals
86	rmt_sig_in3	0	no	ledc_ls_sig_out7	1'd1
87	rmt_sig_in4	0	no	rmt_sig_out0	1'd1
88	rmt_sig_in5	0	no	rmt_sig_out1	1'd1
89	rmt_sig_in6	0	no	rmt_sig_out2	1'd1
90	rmt_sig_in7	0	no	rmt_sig_out3	1'd1
91	-	-	-	rmt_sig_out4	1'd1
92	-	-	-	rmt_sig_out6	1'd1
94	-	-	-	rmt_sig_out7	1'd1
95	I2CEXT1_SCL_in	1	no	I2CEXT1_SCL_out	1'd1
96	I2CEXT1_SDA_in	1	no	I2CEXT1_SDA_out	1'd1
97	host_card_detect_n_1	0	no	host_ccmd_od_pullup_en_n	1'd1
98	host_card_detect_n_2	0	no	host_rst_n_1	1'd1
99	host_card_write_prt_1	0	no	host_rst_n_2	1'd1
100	host_card_write_prt_2	0	no	gpio_sd0_out	1'd1
101	host_card_int_n_1	0	no	gpio_sd1_out	1'd1
102	host_card_int_n_2	0	no	gpio_sd2_out	1'd1
103	pwm1_sync0_in	0	no	gpio_sd3_out	1'd1
104	pwm1_sync1_in	0	no	gpio_sd4_out	1'd1
105	pwm1_sync2_in	0	no	gpio_sd5_out	1'd1
106	pwm1_f0_in	0	no	gpio_sd6_out	1'd1
107	pwm1_f1_in	0	no	gpio_sd7_out	1'd1
108	pwm1_f2_in	0	no	pwm1_out0a	1'd1
109	pwm0_cap0_in	0	no	pwm1_out0b	1'd1
110	pwm0_cap1_in	0	no	pwm1_out1a	1'd1
111	pwm0_cap2_in	0	no	pwm1_out1b	1'd1
112	pwm1_cap0_in	0	no	pwm1_out2a	1'd1
113	pwm1_cap1_in	0	no	pwm1_out2b	1'd1
114	pwm1_cap2_in	0	no	pwm2_out1h	1'd1
115	pwm2_flt_a	1	no	pwm2_out1l	1'd1
116	pwm2_flt_b	1	no	pwm2_out2h	1'd1
117	pwm2_cap1_in	0	no	pwm2_out2l	1'd1
118	pwm2_cap2_in	0	no	pwm2_out3h	1'd1
119	pwm2_cap3_in	0	no	pwm2_out3l	1'd1
120	pwm3_flt_a	1	no	pwm2_out4h	1'd1
121	pwm3_flt_b	1	no	pwm2_out4l	1'd1
122	pwm3_cap1_in	0	no	-	1'd1
123	pwm3_cap2_in	0	no	-	1'd1
124	pwm3_cap3_in	0	no	-	1'd1
140	I2S0I_DATA_in0	0	no	I2S0O_DATA_out0	1'd1
141	I2S0I_DATA_in1	0	no	I2S0O_DATA_out1	1'd1
142	I2S0I_DATA_in2	0	no	I2S0O_DATA_out2	1'd1

Signal No.	Input signals	Default value if unassigned	Same input signal from IO_MUX core	Output signals	Output enable of output signals
143	I2S0I_DATA_in3	0	no	I2S0O_DATA_out3	1'd1
144	I2S0I_DATA_in4	0	no	I2S0O_DATA_out4	1'd1
145	I2S0I_DATA_in5	0	no	I2S0O_DATA_out5	1'd1
146	I2S0I_DATA_in6	0	no	I2S0O_DATA_out6	1'd1
147	I2S0I_DATA_in7	0	no	I2S0O_DATA_out7	1'd1
148	I2S0I_DATA_in8	0	no	I2S0O_DATA_out8	1'd1
149	I2S0I_DATA_in9	0	no	I2S0O_DATA_out9	1'd1
150	I2S0I_DATA_in10	0	no	I2S0O_DATA_out10	1'd1
151	I2S0I_DATA_in11	0	no	I2S0O_DATA_out11	1'd1
152	I2S0I_DATA_in12	0	no	I2S0O_DATA_out12	1'd1
153	I2S0I_DATA_in13	0	no	I2S0O_DATA_out13	1'd1
154	I2S0I_DATA_in14	0	no	I2S0O_DATA_out14	1'd1
155	I2S0I_DATA_in15	0	no	I2S0O_DATA_out15	1'd1
156	-	-	-	I2S0O_DATA_out16	1'd1
157	-	-	-	I2S0O_DATA_out17	1'd1
158	-	-	-	I2S0O_DATA_out18	1'd1
159	-	-	-	I2S0O_DATA_out19	1'd1
160	-	-	-	I2S0O_DATA_out20	1'd1
161	-	-	-	I2S0O_DATA_out21	1'd1
162	-	-	-	I2S0O_DATA_out22	1'd1
163	-	-	-	I2S0O_DATA_out23	1'd1
164	I2S1I_BCK_in	0	no	I2S1I_BCK_out	1'd1
165	I2S1I_WS_in	0	no	I2S1I_WS_out	1'd1
166	I2S1I_DATA_in0	0	no	I2S1O_DATA_out0	1'd1
167	I2S1I_DATA_in1	0	no	I2S1O_DATA_out1	1'd1
168	I2S1I_DATA_in2	0	no	I2S1O_DATA_out2	1'd1
169	I2S1I_DATA_in3	0	no	I2S1O_DATA_out3	1'd1
170	I2S1I_DATA_in4	0	no	I2S1O_DATA_out4	1'd1
171	I2S1I_DATA_in5	0	no	I2S1O_DATA_out5	1'd1
172	I2S1I_DATA_in6	0	no	I2S1O_DATA_out6	1'd1
173	I2S1I_DATA_in7	0	no	I2S1O_DATA_out7	1'd1
174	I2S1I_DATA_in8	0	no	I2S1O_DATA_out8	1'd1
175	I2S1I_DATA_in9	0	no	I2S1O_DATA_out9	1'd1
176	I2S1I_DATA_in10	0	no	I2S1O_DATA_out10	1'd1
177	I2S1I_DATA_in11	0	no	I2S1O_DATA_out11	1'd1
178	I2S1I_DATA_in12	0	no	I2S1O_DATA_out12	1'd1
179	I2S1I_DATA_in13	0	no	I2S1O_DATA_out13	1'd1
180	I2S1I_DATA_in14	0	no	I2S1O_DATA_out14	1'd1
181	I2S1I_DATA_in15	0	no	I2S1O_DATA_out15	1'd1
182	-	-	-	I2S1O_DATA_out16	1'd1
183	-	-	-	I2S1O_DATA_out17	1'd1

Signal No.	Input signals	Default value if unassigned	Same input signal from IO_MUX core	Output signals	Output enable of output signals
184	-	-	-	I2S1O_DATA_out18	1'd1
185	-	-	-	I2S1O_DATA_out19	1'd1
186	-	-	-	I2S1O_DATA_out20	1'd1
187	-	-	-	I2S1O_DATA_out21	1'd1
188	-	-	-	I2S1O_DATA_out22	1'd1
189	-	-	-	I2S1O_DATA_out23	1'd1
190	I2S0I_H_SYNC	0	no	pwm3_out1h	1'd1
191	I2S0I_V_SYNC	0	no	pwm3_out1l	1'd1
192	I2S0I_H_ENABLE	0	no	pwm3_out2h	1'd1
193	I2S1I_H_SYNC	0	no	pwm3_out2l	1'd1
194	I2S1I_V_SYNC	0	no	pwm3_out3h	1'd1
195	I2S1I_H_ENABLE	0	no	pwm3_out3l	1'd1
196	-	-	-	pwm3_out4h	1'd1
197	-	-	-	pwm3_out4l	1'd1
198	U2RXD_in	0	yes	U2TXD_out	1'd1
199	U2CTS_in	0	yes	U2RTS_out	1'd1
200	<a href="#">emac_mdc_i</a>	0	no	<a href="#">emac_mdc_o</a>	<a href="#">emac_mdc_oe</a>
201	<a href="#">emac_md_i</a>	0	no	<a href="#">emac_mdo_o</a>	<a href="#">emac_mdo_o_e</a>
202	<a href="#">emac_crs_i</a>	0	no	<a href="#">emac_crs_o</a>	<a href="#">emac_crs_oe</a>
203	<a href="#">emac_col_i</a>	0	no	<a href="#">emac_col_o</a>	<a href="#">emac_col_oe</a>
204	pcmfsync_in	0	no	bt_audio0_irq	1'd1
205	pcmclk_in	0	no	bt_audio1_irq	1'd1
206	pcmdin	0	no	bt_audio2_irq	1'd1
207	-	-	-	ble_audio0_irq	1'd1
208	-	-	-	ble_audio1_irq	1'd1
209	-	-	-	ble_audio2_irq	1'd1
210	-	-	-	pcmfsync_out	pcmfsync_en
211	-	-	-	pcmclk_out	pcmclk_en
212	-	-	-	pcmdout	pcmdout_en
213	-	-	-	ble_audio_sync0_p	1'd1
214	-	-	-	ble_audio_sync1_p	1'd1
215	-	-	-	ble_audio_sync2_p	1'd1
224	-	-	-	sig_in_func224	1'd1
225	-	-	-	sig_in_func225	1'd1
226	-	-	-	sig_in_func226	1'd1
227	-	-	-	sig_in_func227	1'd1
228	-	-	-	sig_in_func228	1'd1

## A.3. Ethernet\_MAC

Table 25: Ethernet\_MAC

PIN Name	Function6	MII (int_osc)	MII (ext_osc)	RMII (int_osc)	RMII (ext_osc)
GPIO0	EMAC_TX_CLK	TX_CLK (I)	TX_CLK (I)	CLK_OUT(O)	EXT_OSC_CLK(I)
GPIO5	EMAC_RX_CLK	RX_CLK (I)	RX_CLK (I)	-	-
GPIO21	EMAC_TX_EN	TX_EN(O)	TX_EN(O)	TX_EN(O)	TX_EN(O)
GPIO19	EMAC_TXD0	TXD[0](O)	TXD[0](O)	TXD[0](O)	TXD[0](O)
GPIO22	EMAC_TXD1	TXD[1](O)	TXD[1](O)	TXD[1](O)	TXD[1](O)
MTMS	EMAC_TXD2	TXD[2](O)	TXD[2](O)	-	-
MTDI	EMAC_TXD3	TXD[3](O)	TXD[3](O)	-	-
MTCK	EMAC_RX_ER	RX_ER(I)	RX_ER(I)	-	-
GPIO27	EMAC_RX_DV	RX_DV(I)	RX_DV(I)	CRS_DV(I)	CRS_DV(I)
GPIO25	EMAC_RXD0	RXD[0](I)	RXD[0](I)	RXD[0](I)	RXD[0](I)
GPIO26	EMAC_RXD1	RXD[1](I)	RXD[1](I)	RXD[1](I)	RXD[1](I)
U0TXD	EMAC_RXD2	RXD[2](I)	RXD[2](I)	-	-
MTDO	EMAC_RXD3	RXD[3](I)	RXD[3](I)	-	-
GPIO16	EMAC_CLK_OUT	CLK_OUT(O)	-	CLK_OUT(O)	-
GPIO17	EMAC_CLK_OUT_180	CLK_OUT_180(O)	-	CLK_OUT_180(O)	-
GPIO4	EMAC_TX_ER	TX_ERR(O)*	TX_ERR(O)*	-	-
In GPIO Matrix*	-	MDC(O)	MDC(O)	MDC(O)	MDC(O)
In GPIO Matrix*	-	MDIO(IO)	MDIO(IO)	MDIO(IO)	MDIO(IO)
In GPIO Matrix*	-	CRS(I)	CRS(I)	-	-
In GPIO Matrix*	-	COL(I)	COL(I)	-	-

\*Notes: 1. The GPIO Matrix can be any GPIO. 2. The TX\_ERR (O) is optional.

## A.4. IO\_MUX

For the list of IO\_MUX pins, please see the next page.



IO\_MUX

Pin No.	Power Supply Pin	Analog Pin	Digital Pin	Power Domain	Analog Function1	Analog Function2	Analog Function3	RTC Function1	RTC Function2	Function1	Type	Function2	Type	Function3	Type	Function4	Type	Function5	Type	Function6	Type	Drive Strength (2'd2: 20 mA)	At Reset	After Reset	
1	VDDA			VANA in																					
2		LNA_IN		VANA in																					
3	VDD3P3			VANA in																					
4	VDD3P3			VANA in																					
5		SENSOR_VP		VRTC	ADC_H	ADC1_CH0		RTC_GPIO0		GPIO36	I			GPIO36	I									ie=0	
6		SENSOR_CAPN		VRTC	ADC_H	ADC1_CH1		RTC_GPIO1		GPIO37	I			GPIO37	I									ie=0	
7		SENSOR_CAPN		VRTC	ADC_H	ADC1_CH2		RTC_GPIO2		GPIO38	I			GPIO38	I									ie=0	
8		SENSOR_VN		VRTC	ADC_H	ADC1_CH3		RTC_GPIO3		GPIO39	I			GPIO39	I									ie=0	
9		CHIP_PU		VRTC																					
10		VDET_1		VRTC		ADC1_CH6		RTC_GPIO4		GPIO34	I			GPIO34	I									ie=0	
11		VDET_2		VRTC		ADC1_CH7		RTC_GPIO5		GPIO35	I			GPIO35	I									ie=0	
12		32K_XP		VRTC	XTAL_32K_P	ADC1_CH4	TOUCH9	RTC_GPIO9		GPIO32	I/O/T			GPIO32	I/O/T							2'd2		ie=0	
13		32K_XN		VRTC	XTAL_32K_N	ADC1_CH5	TOUCH8	RTC_GPIO8		GPIO33	I/O/T			GPIO33	I/O/T							2'd2		ie=0	
14			GPIO25	VRTC	DAC_1	ADC2_CH8		RTC_GPIO6		GPIO25	I/O/T			GPIO25	I/O/T						EMAC_RXD0	I	2'd2		ie=0
15			GPIO26	VRTC	DAC_2	ADC2_CH9		RTC_GPIO7		GPIO26	I/O/T			GPIO26	I/O/T						EMAC_RXD1	I	2'd2		ie=0
16			GPIO27	VRTC		ADC2_CH7	TOUCH7	RTC_GPIO17		GPIO27	I/O/T			GPIO27	I/O/T						EMAC_RX_DV	I	2'd2		ie=1
17		MTMS		VRTC		ADC2_CH6	TOUCH6	RTC_GPIO16	MTMS	I0	HSPICLK	I/O/T	GPIO14	I/O/T	HS2_CLK	O	SD_CLK	I0	EMAC_TXD2	O	2'd2	wpu, ie=1	wpu, ie=1		
18		MTDI		VRTC		ADC2_CH5	TOUCH5	RTC_GPIO15	MTDI	I1	HSPIO	I/O/T	GPIO12	I/O/T	HS2_DATA2	I1/O/T	SD_DATA2	I1/O/T	EMAC_TXD3	O	2'd2	wpd, ie=1	wpd, ie=1		
19	VDD3P3_RTC			VRTC supply in																					
20			MTCK	VRTC		ADC2_CH4	TOUCH4	RTC_GPIO14	MTCK	I1	HSPID	I/O/T	GPIO13	I/O/T	HS2_DATA3	I1/O/T	SD_DATA3	I1/O/T	EMAC_RX_ER	I	2'd2	wpu, ie=1	wpu, ie=1		
21		MTDO		VRTC		ADC2_CH3	TOUCH3	RTC_GPIO13	I2C_SDA	MTDO	O/T	HSPIC0	I/O/T	GPIO15	I/O/T	HS2_CMD	I1/O/T	SD_CMD	I1/O/T	EMAC_RXD3	I	2'd2	wpu, ie=1	wpu, ie=1	
22		GPIO2		VRTC		ADC2_CH2	TOUCH2	RTC_GPIO12	I2C_SCL	GPIO2	I/O/T	HSPWP	I/O/T	GPIO2	I/O/T	HS2_DATA0	I1/O/T	SD_DATA0	I1/O/T			2'd2	wpd, ie=1	wpd, ie=1	
23		GPIO0		VRTC		ADC2_CH1	TOUCH1	RTC_GPIO11	I2C_SDA	GPIO0	I/O/T	CLK_OUT1	O	GPIO0	I/O/T					EMAC_TX_CLK	I	2'd2	wpu, ie=1	wpu, ie=1	
24		GPIO4		VRTC		ADC2_CH0	TOUCH0	RTC_GPIO10	I2C_SDA	GPIO4	I/O/T	HSPHD	I/O/T	GPIO4	I/O/T	HS2_DATA1	I1/O/T	SD_DATA1	I1/O/T	EMAC_TX_ER	O	2'd2	wpd, ie=1	wpd, ie=1	
25			GPIO16	VSDIO						GPIO16	I/O/T			GPIO16	I/O/T	HS1_DATA4	I1/O/T	U2RXD	I1	EMAC_CLK_OUT	O	2'd2		ie=1	
26	VDD_SDIO			VSDIO supply out/in																					
27			GPIO17	VSDIO						GPIO17	I/O/T			GPIO17	I/O/T	HS1_DATA5	I1/O/T	U2TXD	O	EMAC_CLK_OUT_180	O	2'd2		ie=1	
28		SD_DATA_2		VSDIO						SD_DATA2	I1/O/T	SPIHD	I/O/T	GPIO9	I/O/T	HS1_DATA2	I1/O/T	U1RXD	I1			2'd2	wpu, ie=1	wpu, ie=1	
29		SD_DATA_3		VSDIO						SD_DATA3	I0/O/T	SPIWP	I/O/T	GPIO10	I/O/T	HS1_DATA3	I1/O/T	U1TXD	O			2'd2	wpu, ie=1	wpu, ie=1	
30		SD_CMD		VSDIO						SD_CMD	I1/O/T	SPICS0	I/O/T	GPIO11	I/O/T	HS1_CMD	I1/O/T	U1RTS	O			2'd2	wpu, ie=1	wpu, ie=1	
31		SD_CLK		VSDIO						SD_CLK	I0	SPICLK	I/O/T	GPIO6	I/O/T	HS1_CLK	O	U1CTS	I1			2'd2	wpu, ie=1	wpu, ie=1	
32		SD_DATA_0		VSDIO						SD_DATA0	I1/O/T	SPIQ	I/O/T	GPIO7	I/O/T	HS1_DATA0	I1/O/T	U2RTS	O			2'd2	wpu, ie=1	wpu, ie=1	
33		SD_DATA_1		VSDIO						SD_DATA1	I1/O/T	SPID	I/O/T	GPIO8	I/O/T	HS1_DATA1	I1/O/T	U2CTS	I1			2'd2	wpu, ie=1	wpu, ie=1	
34		GPIO5		VIO						GPIO5	I/O/T	VSPIC0	I/O/T	GPIO5	I/O/T	HS1_DATA6	I1/O/T			EMAC_RX_CLK	I	2'd2	wpu, ie=1	wpu, ie=1	
35		GPIO18		VIO						GPIO18	I/O/T	VSPICLK	I/O/T	GPIO18	I/O/T	HS1_DATA7	I1/O/T					2'd2		ie=1	
36		GPIO23		VIO						GPIO23	I/O/T	VSPID	I/O/T	GPIO23	I/O/T	HS1_STROBE	I0					2'd2		ie=1	
37	VDD3P3_CPU			VIO supply in																					
38			GPIO19	VIO						GPIO19	I/O/T	VSPQ	I/O/T	GPIO19	I/O/T	U0CTS	I1			EMAC_TXD0	O	2'd2		ie=1	
39			GPIO22	VIO						GPIO22	I/O/T	VSPWP	I/O/T	GPIO22	I/O/T	U0RTS	O			EMAC_TXD1	O	2'd2		ie=1	
40		U0RXD		VIO						U0RXD	I1	CLK_OUT2	O	GPIO3	I/O/T							2'd2	wpu, ie=1	wpu, ie=1	
41		U0TXD		VIO						U0TXD	O	CLK_OUT3	O	GPIO1	I/O/T					EMAC_RXD2	I	2'd2	wpu, ie=1	wpu, ie=1	
42			GPIO21	VIO						GPIO21	I/O/T	VSPHD	I/O/T	GPIO21	I/O/T					EMAC_TX_EN	O	2'd2		ie=1	
43	VDDA			VANA in																					
44		XTAL_N		VANA																					
45		XTAL_P		VANA																					
46	VDDA			VANA																					
47		CAP2		VANA																					
48		CAP1		VANA																					
Total Number	8	14	26																						

Note:  
Please see Table: Notes on ESP32 Pin Lists for more information. (请参考表：管脚清单说明。)

## Revision History

Date	Version	Release notes
2018.07	V2.4	<ul style="list-style-type: none"> <li>Deleted information on Packet Traffic Arbitration (PTA);</li> <li>Added Figure 5: ESP32 Power-up and Reset Timing in Section 2.3: Power Scheme;</li> <li>Added the power consumption of dual-core SoCs in Table 5: Power Consumption by Power Modes;</li> <li>Updated section 4.1.2: Analog-to-Digital Converter (ADC).</li> </ul>
2018.06	V2.3	Added the power consumption at CPU frequency of 160 MHz in Table 5: Power Consumption by Power Modes.
2018.05	V2.2	<ul style="list-style-type: none"> <li>Changed the voltage range of VDD3P3_RTC from 1.8-3.6V to 2.3-3.6V in Table 1: Pin Description;</li> <li>Updated Section 2.3: Power Scheme;</li> <li>Updated Section 3.1.3: External Flash and SRAM;</li> <li>Updated Table 5: Power Consumption by Power Modes;</li> <li>Deleted content about temperature sensor;</li> </ul> <p>Changes to electrical characteristics:</p> <ul style="list-style-type: none"> <li>Updated Table 10: Absolute Maximum Ratings;</li> <li>Added Table 11: Recommended Operating Conditions;</li> <li>Added Table 12: DC Characteristics;</li> <li>Added Table 13: Reliability Qualifications;</li> <li>Updated the values of "Gain control step" and "Adjacent channel transmit power" in Table 17: Transmitter Characteristics - Basic Data Rate;</li> <li>Updated the values of "Gain control step", "<math>\pi/4</math> DQPSK modulation accuracy", "8 DPSK modulation accuracy" and "In-band spurious emissions" in Table 19: Transmitter Characteristics – Enhanced Data Rate;</li> <li>Updated the values of "Gain control step", "Adjacent channel transmit power" in Table 21: Transmitter Characteristics - BLE.</li> </ul>
2018.01	V2.1	<ul style="list-style-type: none"> <li>Deleted software-specific features;</li> <li>Deleted information on LNA pre-amplifier;</li> <li>Specified the CPU speed and flash speed of ESP32-D2WD;</li> <li>Added notes to Section 2.3: Power Scheme.</li> </ul>
2017.12	V2.0	Added a note on the sequence of pin number in Chapter 6.
2017.10	V1.9	<ul style="list-style-type: none"> <li>Updated the description of the pin CHIP_PU in Table 1;</li> <li>Added a note to Section 2.3: Power Scheme;</li> <li>Updated the description of the chip's system reset in Section 2.4: Strapping Pins;</li> <li>Added a description of antenna diversity and selection to Section 3.5.1;</li> <li>Deleted "Association sleep pattern" in Table 5 and added notes to Active sleep and Modem-sleep.</li> </ul>
2017.08	V1.8	<ul style="list-style-type: none"> <li>Added Table 4.2 in Section 4;</li> <li>Corrected a typo in Figure 1.</li> </ul>

Date	Version	Release notes
2017.08	V1.7	<ul style="list-style-type: none"> <li>• Changed the transmitting power to +12 dBm; the sensitivity of NZIF receiver to -97 dBm in Section 1.3;</li> <li>• Added a note to Table 2.2 Pin Description;</li> <li>• Added 160 MHz clock frequency in section 3.1.1;</li> <li>• Changed the transmitting power from 21 dBm to 20.5 dBm in Section 3.5.1;</li> <li>• Changed the dynamic control range of class-1, class-2 and class-3 transmit output powers to "up to 24 dBm"; and changed the dynamic range of NZIF receiver sensitivity to "over 97 dB" in Section 3.6.1;</li> <li>• Updated Table 5: Power Consumption by Power Modes, and added two notes to it;</li> <li>• Updated sections 4.1.1, 4.1.9;</li> <li>• Updated Table 10: Absolute Maximum Ratings;</li> <li>• Updated Table 14: RF Power Consumption Specifications, and changed the duty cycle on which the transmitters' measurements are based by 50%.</li> <li>• Updated Table 15: Wi-Fi Radio Characteristics and added a note on "Output impedance" to it;</li> <li>• Updated parameter "Sensitivity" in Table 16, 18, 20;</li> <li>• Updated parameters "RF transmit power" and "RF power control range", and added parameter "Gain control step" in Table 17, 19, 21;</li> <li>• Deleted Chapters: "Touch Sensor" and "Code Examples";</li> <li>• Added a link to <a href="#">certification download</a>.</li> </ul>
2017.06	V1.6	<p>Corrected two typos:</p> <ul style="list-style-type: none"> <li>• Changed the number of external components to 20 in Section 1.1.2;</li> <li>• Changed the number of GPIO pins to 34 in Section 4.1.1.</li> </ul>
2017.06	V1.5	<ul style="list-style-type: none"> <li>• Changed the power supply range in Section: 1.4.1 CPU and Memory;</li> <li>• Updated the note in Section 2.3: Power Scheme;</li> <li>• Updated Table 10: Absolute Maximum Ratings;</li> <li>• Changed the drive strength values of the digital output pins in Note 8, in Table 23: Notes on ESP32 Pin Lists;</li> <li>• Added the option to subscribe for notifications of documentation changes.</li> </ul>
2017.05	V1.4	<ul style="list-style-type: none"> <li>• Added a note to the frequency of the external crystal oscillator in Section 1.4.2: Clocks and Timers;</li> <li>• Added a note to Section 2.4: Strapping Pins;</li> <li>• Updated Section 3.7: RTC and Low-Power Management;</li> <li>• Changed the maximum driving capability from 12 mA to 80 mA, in Table 10: Absolute Maximum Ratings;</li> <li>• Changed the input impedance value of 50Ω, in Table 15: Wi-Fi Radio Characteristics, to output impedance value of 30+j10 Ω;</li> <li>• Added a note to No.8 in Table 23: Notes on ESP32 Pin Lists;</li> <li>• Deleted GPIO20 in Table IO_MUX.</li> </ul>
2017.04	V1.3	<ul style="list-style-type: none"> <li>• Added Appendix: <a href="#">ESP32 Pin Lists</a>;</li> <li>• Updated Table: <a href="#">Wi-Fi Radio Characteristics</a>;</li> <li>• Updated Figure: <a href="#">ESP32 Pin Layout (for QFN 5*5)</a>.</li> </ul>
2017.03	V1.2	<ul style="list-style-type: none"> <li>• Added a note to Table: <a href="#">Pin Description</a>;</li> <li>• Updated the note in Section: <a href="#">Internal Memory</a>.</li> </ul>

Date	Version	Release notes
2017.02	V1.1	<ul style="list-style-type: none"><li>• Added Chapter: <a href="#">Part Number and Ordering Information</a>;</li><li>• Updated Section: <a href="#">MCU and Advanced Features</a>;</li><li>• Updated Section: <a href="#">Block Diagram</a>;</li><li>• Updated Chapter: <a href="#">Pin Definitions</a>;</li><li>• Updated Section: <a href="#">CPU and Memory</a>;</li><li>• Updated Section: <a href="#">Audio PLL Clock</a>;</li><li>• Updated Section: <a href="#">Absolute Maximum Ratings</a>;</li><li>• Updated Chapter: <a href="#">Package Information</a>;</li><li>• Updated Chapter: <a href="#">Learning Resources</a>.</li></ul>
2016.08	V1.0	First release.