

Bluetooth 4.0 BLE module Datasheet

The most complete, most convenient, the most stable of bluetooth data transmission, remote control, PIO acquisition module

---- Master and slave role in one

---- Remote control without other MCU

---- The PIO data acquisition without other MCU

1. Product parameters

- BT Version: Bluetooth Specification V4.0 BLE
- Send and receive no bytes limit.
- Working frequency: 2.4GHz ISM band
- Modulation method: GFSK(Gaussian Frequency Shift Keying)
- RF Power: -23dbm, -6dbm, 0dbm, 6dbm, can modify through AT Command AT+POWE.
- Speed: Asynchronous: 1-6K Bytes
Synchronous: 1-6K Bytes
- Security: Authentication and encryption
- Service: Central & Peripheral UUID FFE0, FFE1
- Power: +3.3VDC 50mA
- Long range: Open space have 100 Meters with iphone4s
- Power: In sleep mode 60uA~1.5mA, Active mode 8.5mA.
- Working temperature: -5 ~ +65 Centigrade
- HM-10 size: 26.9mm x 13mm x 2.2 mm;

2. Product overview

- HM Bluetooth module use CSR BlueCore or TI CC2540, Master and slave roles in one, transmission version and remote control version and PIO state acquisition functions in one, Support the AT command modify module parameters, Convenient and flexible.
- Transmission version can be used to transmit data between two Bluetooth devices.
- Remote Control version can be used to Control PIO ports output high or low level without

any other MCU.

- The PIO state acquisition version can be used to acquisition PIO ports state without any other MCU. (Only support Bluetooth V2.1)
- HM-10 is Bluetooth V4.0 BLE version. Use TI Chip.

3. Product technical specifications

3.1 HM-10 Schematic

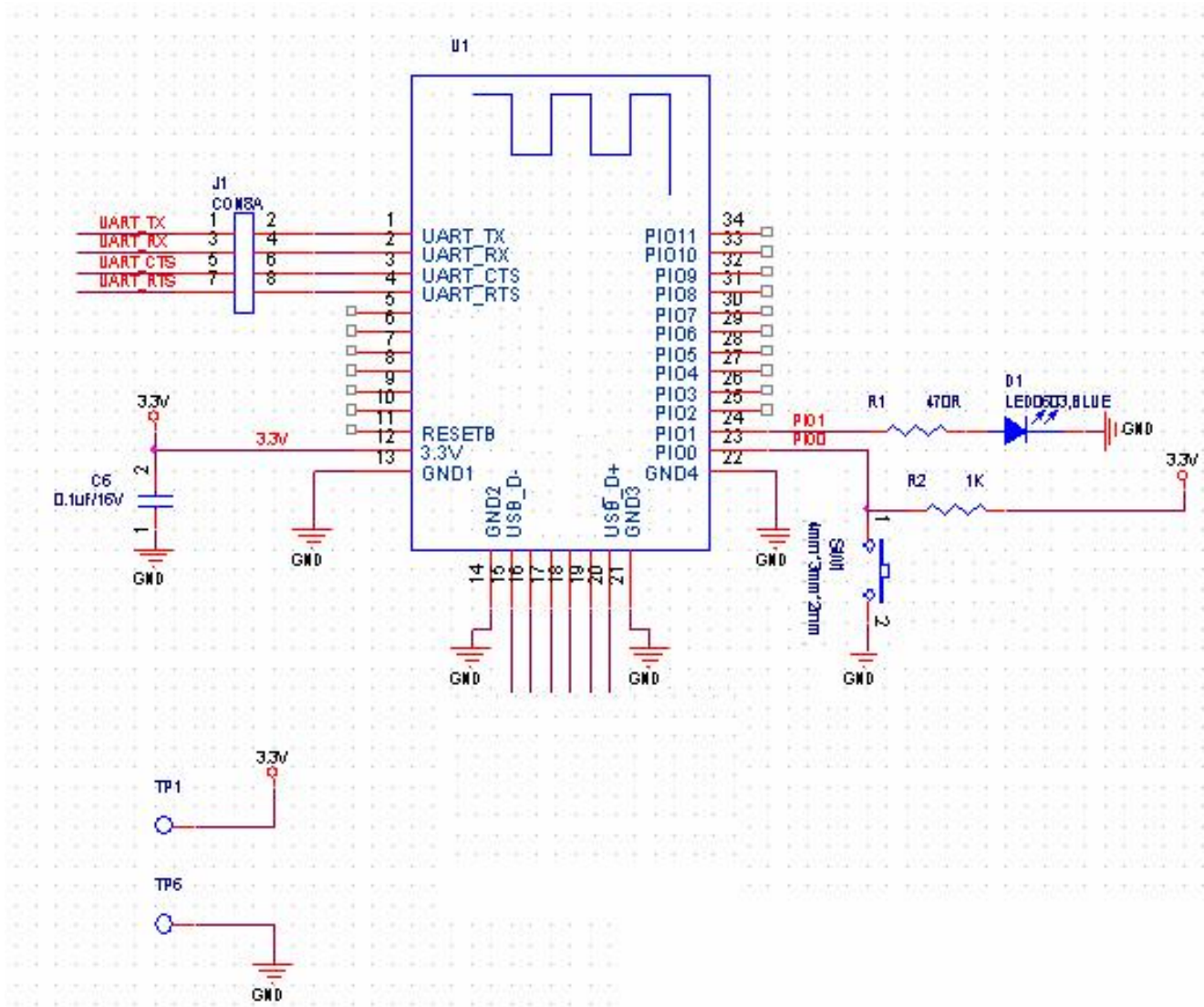

3.2 HM-10 Size

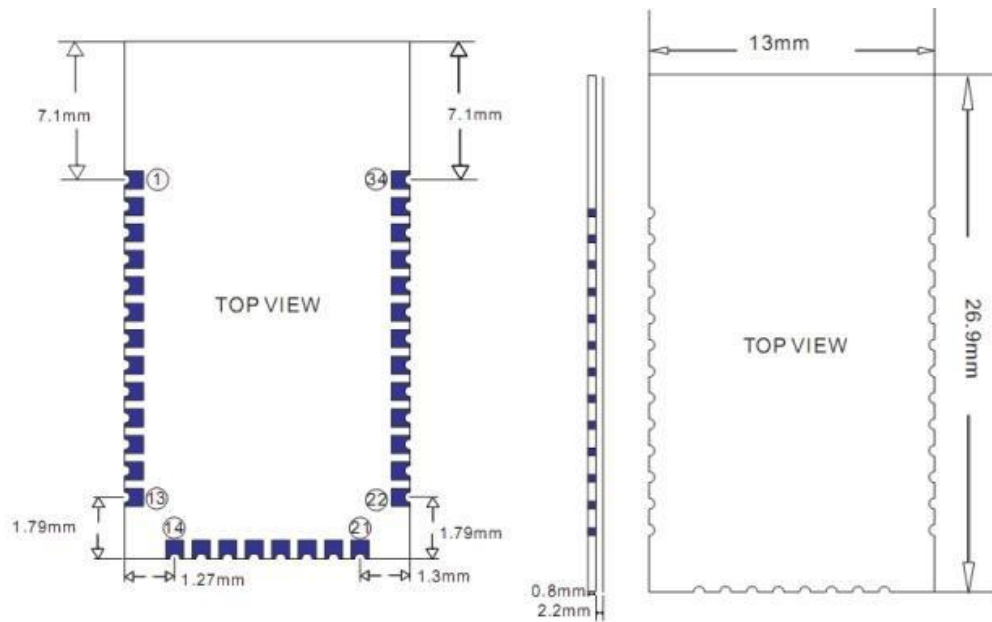

3.3 HM-10 Device Terminal Functions

No	Name	Description	CC254X
1	UART_TX	UART interface	P1_6
2	UART_RX	UART interface	P1_7
3	UART_CTS	UART interface	P1_4
4	UART_RTS	UART interface	P1_5
5	NC	NC	
6	NC	NC	
7	NC	NC	P2_2
8	NC	NC	P2_1
9	NC	NC	P2_0
10	NC	NC	
11	RESETB	Reset if low >100ms.	RESET_N
12	VCC	3.3V	
13	GND	Ground	
14	GND	Ground	
15	USB_D-	USB interface	PIN3
16	NC	NC	
17	NC	NC	
18	NC	NC	
19	NC	NC	
20	UB_D+	USB interface	PIN2
21	GND	Ground	GND
22	GND	Ground	GND
23	PIO0	System Key	P1_3
24	PIO1	System LED	P1_2
25	PIO2	input/output pin. PWM output	P1_1
26	PIO3	input/output pin/ADC	P1_0
27	PIO4	input/output pin/ADC	P0_7

28	PIO5	input/output pin/ADC	P0_6
29	PIO6	input/output pin/ADC	P0_5
30	PIO7	input/output pin/ADC	P0_4
31	PIO8	input/output pin/ADC	P0_3
32	PIO9	input/output pin/ADC	P0_2
33	PIO10	input/output pin/ADC	P0_1
34	PIO11	input/output pin/	P0_0
		ADC/DS18B20/DHT11	

4. System function

1) How to wake up module from sleep mode?

There are two ways to wake up module from sleep mode.

- a) Send "I am iron man, I am iron man, I am iron man I am iron....." string.
Yes, that is a joke, in sleep mode, you can send a long string (Length >80 or more), that string can made module wake up, and you will receive "OK+WAKE" string through UART. That string can't include any AT commands.
- b) Long press system KEY >=1000 ms.

After wake up module, you can send and receive AT commands.

2) How to let module into sleep mode?

In discoverable mode, send "AT+SLEEP" string through UART, if all is okay, module will return "OK+SLEEP" string and into sleep mode.

3) System advert packet

In iOS can't get model MAC address directly. So we put MAC address information into advert packet.

You can use CB Advertisement Data Manufacture Data Key property to get it, string format like follow:

0x48, 0x4D, 0xB4, 0x99, 0x4C, 0xXX, 0xXX, 0xXX

0x48 and 0x4D is "HM" string.

0xB4: 0x99: 0x4C: 0xXX: 0xXX: 0xXX is BLE MAC Address.

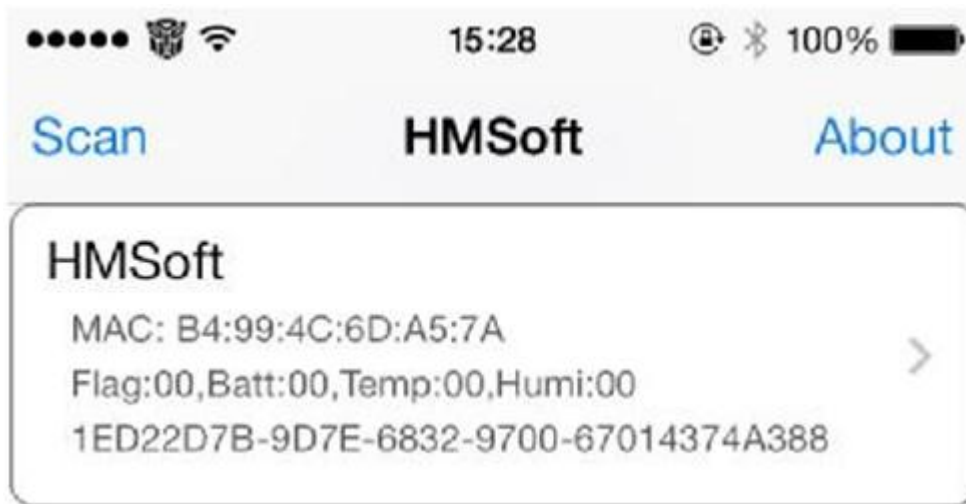

4) System KEY function (PIO0)

Press if Low > 1000ms:

7.3.1 If Module is in sleep mode

Module will wake up immediately, if AT+NOTI value is "1", module will send "OK+WAKE" string through UART.

7.3.2 If Module has already connected to remote device

Module will disconnect from remote device.

7.3.3 If Module is standby mode

Module will reset to default configuration. Then restart.

5) System LED function (PIO1)

In sleep mode, LED has turned off.

If AT+PIO10 is setup

Unconnected status: Output High 500 ms, Low 500 ms

Connected status: Output High

If AT+PIO11 is setup

Unconnected status: Output Low.

Connected status: Output High.

6) System work Mode

A) Mode 0(Transmission mode):

When not connected, through the AT command configuration module, connection,

only for serial data transmission.

B) Mode 1(PIO acquisition mode):

When not connected, through the AT command configuration module, connection,
a) serial data transmission. b) Control of the PIO2,3 output state c) The acquisition of PIO4 ~ 11 input state.

C) Mode 2(Remote control mode):

When not connected, through the AT command configuration module, connection,
a) serial data transmission. b) Control of the PIO2~11 output state.

8 AT Commands

Factory default setting:

Name: HMSoft; Baud: 9600, N, 8, 1; Pin code: 000000; Peripheral Role; transmit mode.

AT Command format:

Uppercase AT command format. string format, without any other symbol. (e.g. \r or \n).

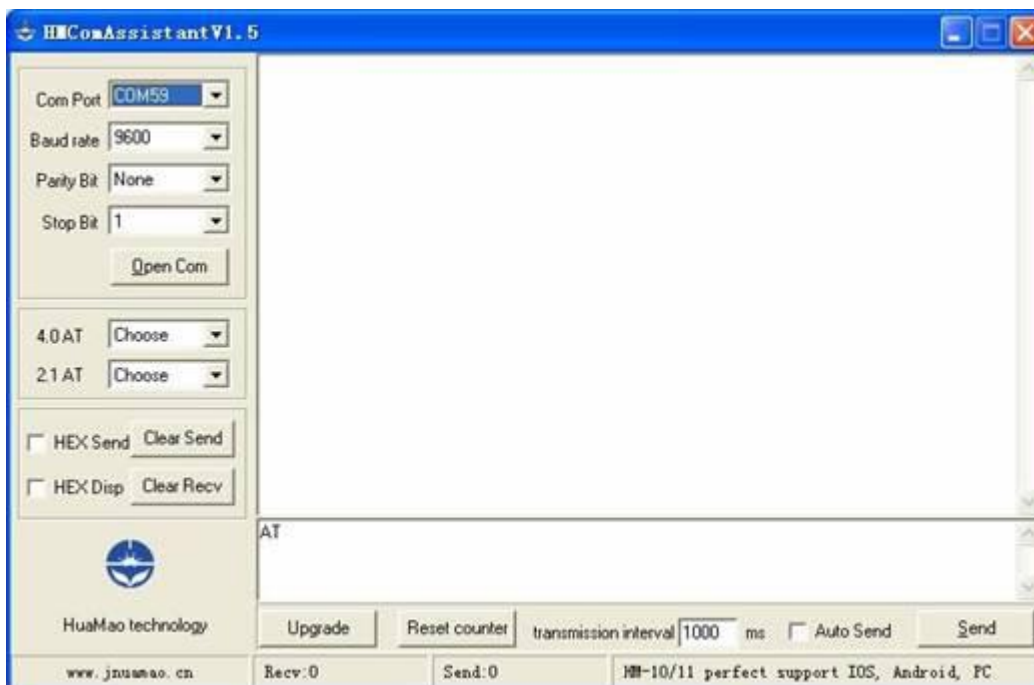

A) On Transmit version: Only accept AT Command from UART interface when Bluetooth device is not connected with remote device.

B) On Remote version: Can accept AT Command from UART interface when Bluetooth Device is not connected with remote device, Also can accept AT Command from remote Bluetooth device when connected that.

C) On PIO collection version: Only accept AT Command from UART interface when Bluetooth device is not connected with remote device.

1. Test Command

Send	Receive	Parameter
AT	OK OK+LOST	None

If Module is not connected to remote device will receive: "OK"

If Module has connected, module will disconnected from remote device, if "AT+NOTI" is setup to 1, will receive: "OK+LOST"

2. Query moduleaddress

Send	Receive	Parameter
AT+ADC[para1]?	OK+GET:0.00	Para1: 3~B map to PIO3~PIOB

3. Query moduleaddress

Send	Receive	Parameter
AT+ADDR?	OK+ADDR:MAC Address	None

4. Query/SetAdvertisinginterval

Send	Receive	Parameter
AT+ADVI?	OK+ Get:[Para]	None
AT+ADVI[Para]	OK+ Set:[Para]	Para: 0 ~ F 0: 100ms 1: 152.5 ms 2: 211.25 ms 3: 318.75 ms 4: 417.5 ms 5: 546.25 ms 6: 760 ms 7: 852.5 ms 8: 1022.5 ms 9: 1285 ms A: 2000ms B: 3000ms C: 4000ms D: 5000ms E: 6000ms F: 7000ms Default: 9 HMSoft Default: 0 HMSensor Default: 9

The maximum 1285ms recommendations form the IOS system. That is to

say, 1285ms is apple allowed, but in response to scan and connected all the time will be long.

5. Query/Set Advertising Type

Send	Receive	Parameter
AT+ADTY?	OK+ Get:[Para]	None
AT+ADTY[Para]	OK+ Set:[Para]	Para: 0 ~ 3 0: Advertising ScanResponse, Connectable 1: Only allow last device connect in 1.28 seconds 2: Only allow Advertising and ScanResponse. 3: Only allow Advertising Default: 0

6. Query/SetANCS switch

Send	Receive	Parameter
AT+ANCS?	OK+ Get:[Para]	None
AT+ANCS[Para]	OK+ Set:[Para]	Para: 0 ~ 1 0: Off 1: On Default: 0

Note1: Please send AT+RESET to restart module if you set value 1.

Note2: Must execute AT+TYPE3 first.

7. Query/Setwhitelist switch

Send	Receive	Parameter
AT+ALLO?	OK+ Get:[Para]	None

AT+ALLO[Para]	OK+ Set:[Para]	Para: 0 ~ 1 0: Off 1: On Default: 0
---------------	----------------	--

Note1: WhiteList allow three mac address link to module. Please use AT+AD command set whitelist mac address

8. Query/Set whitelist mac address

Send	Receive	Parameter
AT+AD[para1]??	OK+ Get:[Para2]	None
AT+ALLO[Para1][Para2]	OK+ Set:[Para2]	Para1: 1, 2, 3 Para2: MAC address Para1 default: 0

E.g.

Send AT+ID1001122334455

Recv OK+Set:001122334455

9. Query/Set Module pin output state, After power supplied

Send	Receive	Parameter
AT+BEFC?	OK+ Get:[Para]	None
AT+BEFC[Para]	OK+ Set:[Para]	Para: 000~ 3FF Default: 000

3FF == 001111111111, left to right side is map to PIO0~PIOB, PIO0 and

Pio1 is used by system. Only Pio2~PIOB pins is available.

e.g. Set PIO2~PIOB all output high after power supplied.

Send: AT+BEFC3FF

Recv:OK+Set:3FF

When next time power on, module PIO2~PIOB will output high. Note:

Query PIO pins current state please use AT+PIO?? Command. Note:

Please don't use this command when "AT+MODE1" is setup.

10. Query/Set Module pin output state, After connection is established

Send	Receive	Parameter
AT+AFTC?	OK+ Get:[Para]	None
AT+AFTC[Para]	OK+ Set:[Para]	Para: 000~ 3FF Default: 000

3FF == 001111111111, Left to right side is map to PIO0~PIOB, PIO0 and Pio1 is used by system. Only Pio2~PIOB pins is available.

e.g. Set PIO2~PIOB all output high when connection is established.

Send: AT+AFTC3FF

Recv: OK+Set:3FF

When Bluetooth connection is established, module PIO2~PIOB will output high.

Note: Query PIO pins current state please use “AT+PIO??” command.

Note: Please don't use this command when “AT+MODE1” is setup.

11. Query/Set battery monitor switch

Send	Receive	Parameter
AT+BATC?	OK+ Get:[Para]	None
AT+BATC[Para]	OK+ Set:[Para]	Para: 0 ~ 1 0: Off 1: On Default: 0

12. Query battery information

Send	Receive	Parameter
AT+BATT?	OK+BATT:[Para]	Para: 000~100

There has three ways to get battery information:

- Before establishing a connection, Send “AT+BATT?” through UART.
- After established a connection, In Mode 1 or 2, remote side send “AT+BATT?”

Battery information has included in scan response data package, one hour update once. You can use Android or IOS discovery module, when module has been discovered, you can get it from scan result array.

Data format is 0x02, 0x16, 0x00, 0xB0, [FLAG], [temperature], [humidity],
[battery].

Android:

Included in OnLeScan function result array, you can see it direct.

```
private BluetoothAdapter.LeScanCallback mLeScanCallback = new BluetoothAdapter.LeScanCallback() {
```

```
    @Override

    public void onLeScan(final BluetoothDevice device, int rssi, byte[]

        scanRecord) {

        .....<Other code>.....

        String sBatt = ""; //Battery

        String sTemp = ""; //Temperature
        String sHumi = ""; //Humidity

        for(int i = 0; i < scanRecord.length; i++)

        {

            if(i + 7 < scanRecord.length)

            {

                //Since V522

                if(scanRecord[i] == 0x07 && scanRecord[i + 1] == 0x16

                    && scanRecord[i + 2] == 0x00 && scanRecord[i + 3] == 0xB0)

                {

                    if(scanRecord[i + 7] > 0)

                        sBatt = String.valueOf(scanRecord[i + 7]);

                    if(scanRecord[i + 5] > 0)

                        sTemp = String.valueOf(scanRecord[i + 5]);

                    if(scanRecord[i + 6] > 0)

                        sHumi = String.valueOf(scanRecord[i + 6]);

                }

            }

            .....<Other code>.....

        }

    }

};
```

iOS:

Included in LeScan function result NSDictionary struct, service id is 0xB000

13. Query/Set Bit format

Send	Receive	Parameter
AT+BIT7?	OK+Get:[para1]	Para1: bit7 switch.
AT+BIT7[para1]	OK+Set:[para1]	0-----Not compatible 1-----Compatible Default: 0

This command is used only for compatible uses 7 data bits, 2 stop bit device.

14. Query/Set baud rate

Send	Receive	Parameter
AT+BAUD?	OK+Get:[para1]	Para1: Baud rate No.
AT+BAUD[para1]	OK+Set:[para1]	0-----9600 1-----19200 2-----38400 3-----57600 4-----115200 5-----4800 6-----2400 7-----1200 8-----230400 Default: 0(9600)

e.g.

Query baud:

Send: AT+BAUD?, Receive: OK+Get:0

Setup baud:

Send: AT+BAUD1, Receive: OK+Set:1

Note: If setup to Value 7, After next power on, module will not support any AT Commands, until PIO0 is pressed, Module will change Baud to 9600.

15. Query/Set Minimum Link Layer connection interval

Send	Receive	Parameter
AT+COMI?	OK+Get:[P1]	P1: 0 ~ 9
AT+COMI[P1]	OK+Set:[P1]	Default: 3(20ms)

P1 Value: 0: 7.5ms; 1: 10ms; 2: 15ms; 3: 20ms; 4: 25ms; 5: 30ms; 6: 35ms; 7: 40ms; 8: 45ms; 9: 4000ms

16. Query/Set Maximum Link Layer connection interval

Send	Receive	Parameter
AT+COMA?	OK+Get:[P1]	P1: 0 ~ 9
AT+COMA[P1]	OK+Set:[P1]	Default: 7(40ms)

P1 Value: 0: 7.5ms; 1: 10ms; 2: 15ms; 3: 20ms; 4: 25ms; 5: 30ms; 6: 35ms; 7: 40ms; 8: 45ms; 9: 4000ms

17. Query/Set Link Layer connection slave latency

Send	Receive	Parameter
AT+COLA?	OK+Get:[P1]	P1: 0 ~ 4
AT+COLA[P1]	OK+Set:[P1]	Default: 0

18. Query/Set Maximum Link Layer connection interval

Send	Receive	Parameter
AT+COMA?	OK+Get:[P1]	P1: 0 ~ 6
AT+COMA[P1]	OK+Set:[P1]	Default: 6(6000ms)

P1 Value: 0: 100ms; 1: 1000ms; 2: 2000ms; 3: 3000ms; 4: 4000ms; 5: 5000ms; 6: 6000ms;

19. Query/Set The Switch of update connection parameter

Send	Receive	Parameter
AT+COUP?	OK+Get:[P1]	P1: 0 ~ 1
AT+COUP[P1]	OK+Set:[P1]	0: Don't update 1: Update Default: 1(update)

This command is only use when module is in slave role.

20. Query/Set Characteristic

Send	Receive	Parameter
AT+CHAR?	OK+Get:[para1]	Para1: 0x0001~0xFFFE
AT+CHAR[para1]	OK+Set:[para1]	Default: 0xFFE1

e.g. change characteristic value to 0xAAA0

Send: AT+CHAR0xAAA0

Recv: OK+Set:0xAAA0

21. Clear Last Connected device address

Send	Receive	Parameter
AT+CLEAR	OK+CLEAR	None

Notice: Only Central role is used.

22. Try connect to last succeeded device

Send	Receive	Parameter
AT+CONNL	OK+CONN[Para1]	Para1: L, E, F, N L: Connecting E: Connecterror F: ConnectFail N: No Address

Notice: Only Central role is used. Must set up AT+IMME1 and AT+ROLE1 first.

If remote device has already connected to other device or shut down, "OK+CONN" will received after about 10 seconds.

23. Try connect an address

Send	Receive	Parameter
AT+CO[P0][P1]	OK+CO[P0][P0][P2]	P0: N, 1 N: Normal Address 1: Dual module Addr P1: Address Like: 0017EA090909 P2: A, E, F A: Connecting E: Connect error F: Connect Fail

Notice: Only central role is used. Must set up AT+IMME1 and AT+ROLE1 first.

If remote device has already connected to other device or shut down,

"OK+CONN" will received after about 10 Seconds.

e.g.

Try to connect an device which MAC address is 00:17:EA:09:09:09

Send: AT+CON0017EA090909

May receive a reply:

OK+CONNA ===== Acceptrequest,connecting

OK+CONNE ===== Connect error
 OK+CONN ===== Connected, if AT+NOTI1 is setup
 OK+CONNF ===== Connect Failed, After 10 seconds

24. Query PIO04~PIO11 input(output) state

Send	Receive	Parameter
AT+COL??	OK+ Col:[Para1]	Para1: 0x00~0xFF

Para1 is a byte, has 8 bits, bit 7 ~ bit 0 is map to the PIO4 ~ PIO11.

25. Query/Set PIO collection rate

Send	Receive	Parameter
AT+CYC??	OK+ Get:[para1]	Para1: 00~99
AT+CYC[para1]	OK+ Set:[para1]	Unit: seconds Default: 10

In mode 1, when PIO state is change, module will send OK+Col:[xx] to UART or remote side. This command is set send interval.

26. Start a device discovery scan

Send	Receive	Parameter
AT+DISC?	OK+DIS[P0][P1]	P0: C,0, 1, 2 C: Common string 0~2: Address type P1: S, E, [MAC String] S: Start discovery E: End discovery MAC String: Device MAC string

Please set AT+ROLE1 and AT+IMME1 first.

e.g.

Send: AT+DISC?

Recv: OK+DISCS

Recv: OK+DIS[P0]:123456789012 (discovered device address information)

If AT+SHOW1 is setup, you will receive then Name information as follow

Recv: OK+NAME: xxx

After send Name value, will send two extra “\r\n” value ASCII byte

Recv: OK+DIS[P0]:234567890123

Recv: OK+NAME: xxx

After send Name value, will send two extra “\r\n” value ASCII byte

.....(Before V535 max results is 6, Since V535 not limit)

Recv: OK+DISCE

Connect use array index:

Connect to a discovered device: AT+CONN0, AT+CONN1.....AT+CONN5

Connect use MAC string: AT+CON[MAC String]

27. Connect to an Discovery device

Send	Receive	Parameter
AT+CONN[para1]	OK+CONN[para2]	Para1: 0~5 Para2: E, F, 0~5 E: Link error F: Link failed 0~5: Try to connect

This command is use after execute AT+DISC?

This command will clear all discovery data.

28. Query/Set iBeacon deploy mode

Send	Receive	Parameter
AT+DELO[para1]	OK+DELO[para1]	Para1: 1, 2 1: Allowed to broadcast and scanning 2: Only allow broadcast

After receive OK+DELO[para1], module will reset after 500ms.

This command will let module into non-connectable status until next power on.

29. Remove bond information

Send	Receive	Parameter
AT+ERASE	OK+ERASE	

30. Set advertising data FLAG byte

Send	Receive	Parameter
AT+FLAG[P1]	OK+ Set:[P1]	P1: 0~FF (one byte)

Note: Please ref to AT+BATT? Command.

31. Query/Set filter of HM modules

Send	Receive	Parameter
AT+FILT?	OK+ Get:[para1]	Para1: 0, 1 0: Will find all BLE modules 1: Only find HM Modules Default: 1
AT+FILT[para1]	OK+ Set:[para1]	

32. Query/Set flow control switch

Send	Receive	Parameter
AT+FLOW?	OK+ Get:[para1]	Para1: 0, 1 0: Off 1: On Default: 0
AT+FLOW[para1]	OK+ Set:[para1]	

33. Query/Set module RX gain

Send	Receive	Parameter
AT+GAIN?	OK+ Get:[P1]	P1: 0, 1 0: No RX gain 1: Open RX gain Default: 0
AT+GAIN[P1]	OK+ Set:[P1]	

34. System Help Information

Send	Receive	Parameter
AT+HELP?	Help Information	None

35. Query/Set Module work type

Send	Receive	Parameter
AT+IMME?	OK+ Get:[para1]	Para1: 0, 1 1: When module is powered on, only respond the AT Command, don't do anything. Until AT + START, AT+CON, AT+CONNL commands is received. 0: When power on, module will start work immediately Default: 0
AT+IMME[para1]	OK+ Set:[para1]	

This command is only used for Central role.

36. Query/Set Module iBeacon switch

Send	Receive	Parameter
AT+IBEA?	OK+Get:[para1]	Para1: 0, 1
AT+IBEA[para1]	OK+Set:[para1]	0: Turn off iBeacon 1: Turn on iBeacon

iBeacon UUID is: 74278BDA-B644-4520-8F0C-720EAF059935..

37. Query/Set iBeacon UUID

Send	Receive	Parameter
AT+IBE0?	OK+Get:[para1]	Para1: 00000001~
AT+IBE0[para1]	OK+Set:[para1]	FFFFFFFE Default: 74278BDA

iBeacon UUID is: **74278BDA**-B644-4520-8F0C-720EAF059935. e.g.: Send:
AT+IBE012345678 change iBeacon UUID red color string to "12345678"

This command can change red color string in iBeacon UUID.

38. Query/Set Module iBeacon Marjor version

Send	Receive	Parameter
AT+MARJ?	OK+Get:[para1]	Para1: 0x0001, 0xFFFFE
AT+MARJ[para1]	OK+Set:[para1]	Default: 0xFFE0

E.g. Change marjor version to 0x0102

Send: AT+MARJ0x0102, if all is okay, module will send back OK+Set:
0x0102

39. Query/Set Module iBeacon minor

Send	Receive	Parameter
AT+MINO?	OK+Get:[para1]	Para1: 0x0001, 0xFFFFE
AT+MINO[para1]	OK+Set:[para1]	Default: 0xFFE1

40. Query/Set Module iBeacon Measured power

Send	Receive	Parameter
AT+MEAS?	OK+Get:[para1]	Para1: 0x0001, 0xFFFE
AT+MEAS[para1]	OK+Set:[para1]	Default: 0xFFE1

41. Query/Set Module Work Mode

Send	Receive	Parameter
AT+MODE?	OK+Get:[para1]	Para1: 0, 1, 2
AT+MODE[para1]	OK+Set:[para1]	0: Transmission Mode 1: PIO collection Mode + Mode 0 2: Remote Control Mode + Mode 0

Mode 0:

Before establishing a connection, you can use the AT command configuration module through UART.

After established a connection, you can send data to remote side from each other.

Mode 1:

Before establishing a connection, you can use the AT command configuration module through UART.

After established a connection, you can send data to remote side. Remote side can do fellows:

Send AT command configuration module.

Collect PIO04 to the PIO11 pins input state of HM-10.

Remote control PIO2, PIO3 pins output state of HM-10.

Send data to module UART port (not include any AT command and per package must less than 20 bytes).

Mode 2:

Before establishing a connection, you can use the AT command configuration module through UART.

After established a connection, you can send data to remote side. Remote side can do fellows:

Send AT command configuration module.

Remote control PIO2 to PIO11 pins output state of HM-10.

Send data to module UART port (not include any AT command and per package must less than 20 bytes).

42. Query/SetNotify information

Send	Receive	Parameter
AT+NOTI?	OK+Get:[para1]	Para1: 0, 1
AT+NOTI[para1]	OK+Set:[para1]	0: Don't Notify 1: Notify Default: 0

If this value is set to 1, when link ESTABLISHED or LOSTED module will send OK+CONN or OK+LOST string through UART.

43. Query/Set notify mode

Send	Receive	Parameter
Q: AT+NOTP?	OK+ Get[P1]	P1: 0, 1; default: 0
Q: AT+NOTP[P1]	OK+ Set[P1]	0: without address 1: with address

This command must work with "AT+NOTI1", if this switch is open, when the module connect to disconnect, the prompt string will include the remote address.

OK+CONN:001122334455 String "001122334455" is the MAC address string

44. Query/SetModule name

Send	Receive	Parameter
AT+NAME	OK+NAME[para1]	Para1: module name, Max length is 12. Default: HMSoft
AT+NAME[para1]	OK+Set[para1]	

e.g.: change module name to bill_gates

Send: AT+NAMEbill_gates

Receive: OK+SetName:bill_gates

45. Query/Set output driver power

Send	Receive	Parameter
Query: AT+PCTL?	OK+Get:[para1]	None
Set: AT+PCTL[para1]	OK+Set:[para1]	Para1: 0,1 0:Normal power output 1:Max power output Default: 1

46. Query/Set Parity bit

Send	Receive	Parameter
Query: AT+PARI?	OK+Get:[para1]	None
Set: AT+PARI[para1]	OK+Set:[para1]	Para1: 0,1,2 0:None 1:EVEN 2:ODD Default: 0 (None)

47. Query/Set PIO1 output status (System LED)

Send	Receive	Parameter
AT+PIO1?	OK+Get:[para1]	Para1: 0, 1

AT+ PIO1 [para1]	OK+Set:[para1]	
------------------	----------------	--

48. Query/Set PIO pins output high or low (Only this time, when module next power on, this value is not be used)

Send	Receive	Parameter
AT+PIO[para1]?	OK+PIO:[para1][para2]	Para1: 2~B, ? Para2: 0, 1, ? HM-11 only has 4 pins. Para1 is which PIO pin you want to Query/Set Value: 2,3,4,5,6,7,8,9,A,B. Para2 is Query or setup value.
AT+PIO[para1][para2]	OK+PIO:[para1][para2]	

e.g.

Query PIO2

Send: AT+PIO2?

Setup PIO2 output high

Send: AT+PIO21,

Receive: OK+PIO21

HM-10 HMSensor version: para1 value is 2~A,

HM-10 HMSoft version: para1 value is 2~B

51. Query/Set Pin Code

Send	Receive	Parameter
AT+PASS?	OK+Get:[para1]	Para1 is Pin Code, 000000~999999 Default: 000000
AT+PIN[para1]	OK+Set:[para1]	

e.g.

Query Pin Code

Send: AT+PIN?,

Receive: OK+PIN:000000

Setup Pin Code 008888

Send: AT+PIN008888

Receive: OK+Set:008888

52. Query/SetModule Power

Send	Receive	Parameter
AT+POWE?	OK+Get:[para1]	None
AT+ POWE [para1]	OK+Set:[para1]	Para: 0 ~ 3 0: -23dbm 1: -6dbm 2: 0dbm 3: 6dbm

52. Query/Set Module sleep type

Send	Receive	Parameter
AT+PWRM?	OK+Get:[para1]	None

AT+PWRM[para1]	OK+Set:[para1]	Para1: 0~1 0:Auto sleep 1:don't autosleep
----------------	----------------	---

Only support peripheral role.

53. Query/Set reliable advertising mode

Send	Receive	Parameter
AT+RELI?	OK+ Get:[para1]	Para1: 0, 1
AT+RELI[para1]	OK+ Set:[para1]	0: Normal advertising 1: Reliable advertising Default: 0

54. Restore all setup value to factory setup

Send	Receive	Parameter
AT+RENEW	OK+RENEW	None

55. Restart module

Send	Receive	Parameter
AT+RESET	OK+RESET	None

56. Query/Set Master and Slaver Role

Send	Receive	Parameter
AT+ROLE?	OK+Get:[para1]	Para1: 0, 1
AT+ROLE[para1]	OK+Set:[para1]	0: Peripheral 1: Central Default: 0

57. Query RSSIValue

Send	Receive	Parameter
AT+RSSI?	OK+RSSI:[para1]	None

Require: AT+MODE value > 0

This command only used by Remote device query when connected.

58. Query Last Connected Device Address

Send	Receive	Parameter
AT+RADD?	OK+RADD:MAC Address	None

59. Query/Set Module Sensor work interval

Send	Receive	Parameter
AT+RAT??	OK+Get:[para1]	Para1: 00~99
AT+RAT[para1]	OK+Set:[para1]	0:Save whenconnected 1:Don't Save Default: 0

Note: This command is only use for HMSensor

60. Query/Set Stopbit

Send	Receive	Parameter
AT+STOP?	OK+Get:[para1]	None
AT+STOP[para1]	OK+Set:[para1]	Para1:0, 1 0: One stop bit 1: Two stop bit Default: 0 (One stop bit)

61. Work immediately

Send	Receive	Parameter
AT+START	OK+START	None

This command is only used when AT+IMME1 is setup.

62. Query Module into sleep mode

Send	Receive	Parameter
AT+SLEEP	OK+SLEEP	None

Only support Peripheral role.

63. Query/Set Module save connected address parameter

Send	Receive	Parameter
AT+SAVE?	OK+Get:[para1]	None
AT+SAVE[para1]	OK+Set:[para1]	Para1: 0~1 0:Save whenconnected 1:Don't Save

64. Query/Set sensor type on module PIO11(HM-11 is PIO3)

Send	Receive	Parameter
AT+SENS?	OK+Get:[para1]	Para1: 0, 1, 2
AT+SENS[para1]	OK+Set:[para1]	0: None 1: DHT11 2: DS18B20

Note: This command is use for HMSensor.

65. Query/Set discovery parameter

Send	Receive	Parameter
AT+SHOW?	OK+Get:[para1]	None
AT+SHOW[para1]	OK+Set:[para1]	Para1: 0~1 0:Don't show name 1:Show name Default: 0

Please execute AT+FILT0 first.

If AT+SHOW1 is setup, AT+DISC? Command will show you name information included into scan result package.

66. Query/Set Module Sensor Temperature and humidity(if has a sensor)

Send	Receive	Parameter
AT+TEHU?	OK+Get:[para1][para2]	Para1: 000~120 Para2: 000~100

Note: This command is use for HMSensor.

This value is added into scan response data package.

Data format is 0x02, 0x16, 0x00, 0xB0, [reserved], [temperature],
[humidity], [battery].

Android:

Included in OnLeScan function result array, you can see it direct. iOS:

Included in LeScan function result NSDictionary struct, service id is
0xB000.

67. Query DS18B20 Sensor or IC temperature

Send	Receive	Parameter
AT+TEMP?	OK+Get:[para1]	Para1: 000.000~255.000

Note1: if not setup AT+SENS value, will get IC
temperature.

68. Query/Set module connect remote device timeout value

Send	Receive	Parameter
AT+TCON?	OK+TCON:[para1]	None
AT+TCON[para1]	OK+Set:[para1]	Para1 is timeout value. when time is up module will not connect this address anymore, then enter search mode. Para1 allowed value: 000000~999999 Unit is ms. Default: 000000 Connect forever

This value is only used for Central Role, when module has Last
Connected address.

69. Query/Set Module Bond Mode

Send	Receive	Parameter
AT+TYPE?	OK+Get:[para1]	None

AT+TYPE[para1]	OK+Set:[para1]	Para1: 0~2 0:Not need PIN Code 1:Auth not need PIN 2:Auth with PIN 3:Auth and bond
----------------	----------------	--

Important: If your module version is less than V515, please don't use this command. Under android 4.3 AT+TYPE1 is same to AT+TYPE2.

70. Query/Set service UUID

Send	Receive	Parameter
AT+UUID?	OK+Get:[para1]	Para1: 0x0001~0xFFFE
AT+UUID[para1]	OK+Set:[para1]	Default: 0xFFE0

e.g. Change UUID value to

0xAAA0 Send:

AT+UUID0xAAA0

Recv: OK+Set:0xAAA0

Query/Set UART sleep type